

Collection 2023

Fredericia

It is of great importance
that the things we purchase
and live with do not need
to be changed, but instead
grow old with dignity
and charm.

Andreas Graversen
Fredericia CEO 1955-1995

Fredericia is a family-owned design company established in 1911.

We are co-founders of Danish Modern design.

We believe in clarity, honest materials and human empathy.

Our passion is to
create modern originals
rooted in our heritage
and relevant to a
global audience.

Authentic, purposeful,
sustainable designs.

Crafted to last.

About
8—23

Collection
24—389

Overview
390

Designers
402





Modern originals

Fredericia is a family-owned company founded in 1911. Our history is deeply rooted in the development of Scandinavian furniture design and production. Several of our products have become indisputable classics, and a large portion of our collection has been in continuous production for decades.

At Fredericia, we have always moved forward. We have been developing new products throughout our history, spanning over 100 years. As a result, not only do we have an impressive design archive, we also have a profound knowledge and understanding of furniture design, which has been passed on from generation to generation. Insights and attitudes about design which are continuously being shaped by ongoing developments in production, culture and daily life.

We have a proud spirit that can be traced back to our first workshop – a workshop founded on traditional craftsmanship and modern industrial production.

The company was initially established as Fredericia Stolefabrik (Fredericia Chair Factory). From the very start, Fredericia became known for extremely high-quality furniture in various traditional styles.

In 1955, visionary businessman Andreas Graversen integrated Fredericia's heritage of high-quality furniture with modernist ideals in a close, well-known collaboration with Børge Mogensen. Mogensen's intuitive understanding of materials and strong sense of proportions led to a range of iconic pieces celebrated to this day - by collectors, museums, architects and designers around the world.

Ever since the untimely death of Mogensen in 1972, Fredericia has continuously evolved by staying in tune with the times. Throughout the years, the Graversen family has expanded Fredericia's circle of designers – who each contribute to the renewal and reinterpretation the Fredericia design ethos in new context.

Inspired by the creative power of long-lasting relationships, such as our close collaboration with Mogensen, Fredericia continues to see designer collaborations as partnerships based on a deep mutual trust - forming a creative culture characterised by the integrity of design, artistic expression, material expertise and industry knowledge. Always in an effort to create sustainable furniture that encourages human wellbeing wherever people live, work and relax.

Timeline

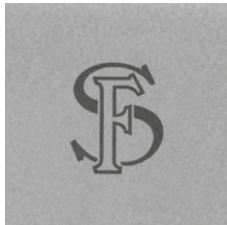

1911
Established
Fredericia Stolefabrik is founded by N.P. Ravnsø.



1923
Upholstery excellence
Fredericia originally specialises in upholstery production. From the start, the products are known for their high level of craftsmanship.

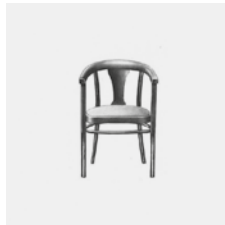

1930
Thonet licence production
Fredericia is licenced production from the Thonet factories. Wood is introduced as a core competence.



1944
J16
Hans J. Wegner
Wegner designs the first version of the J16 for cabinetmaker Johannes Hansen.



1952
Søborg
Børge Mogensen
Mogensen launches a series of steel-legged furniture for Søborg Møbelfabrik and Andreas Graversen's first company, Tage Christensen & Son.



1960
Ox Chair
Hans J. Wegner
At the Furniture Fair in Fredericia, Wegner launches the Ox Chair, made by the AP Workshop.



1913
Furniture Fair established
The Scandinavian Furniture Fair is established in the town of Fredericia.



1938
The Danish School
Wegner, Mogensen and Risom study together in the same class at the School of Arts and Crafts in Copenhagen.



1945
Cabinetmakers' Guild Exhibition
Mogensen and Wegner present a joint exhibition together at the Copenhagen Cabinetmaker's Guild, showcasing exclusive, lightweight furniture.



1955
Graversen and Mogensen
Andreas Graversen acquires Fredericia on the condition that Børge Mogensen would be the sole designer.



1962
2213 Sofa
Børge Mogensen
Fredericia introduces the 2213 Sofa, designed by Mogensen in an effort to create the ultimate upholstered sofa.



1947
J39
Børge Mogensen
Mogensen's J39 is launched by the Danish Cooperative Wholesale Society in Denmark.



1958
The Spanish Chair
Børge Mogensen
The Spanish Chair is launched at the Copenhagen Cabinetmakers' Guild Exhibition and soon becomes an icon of the collaboration between Fredericia and Mogensen.



1964
Corona Chair
Poul M. Volther
Poul M. Volther breaks new ground with the Corona Chair introduced by Erik Jørgensen.

1910

1920

1930

1940

1950

1960



1970
Canvas Chair
Børge Mogensen

Fredericia launches the Canvas Chair, designed by Mogensen as a reaction to the flashy, pop designs of the 1960s.



1984
Rotor Sofa: Foersom & Hiort-Lorenzen

Foersom & Hiort-Lorenzen and Erik Jørgensen launch the Rotor sofa, a successful example of Danish post-modernism.



1989
Graversen and Ditzel

Nanna Ditzel and Fredericia second generation Thomas Graversen present a range of avant-garde furniture.

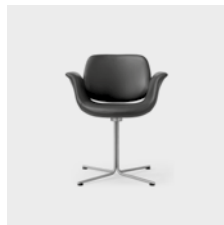

2003
Flamingo: Foersom & Hiort-Lorenzen

Foersom & Hiort-Lorenzen design the Flamingo Chair for Erik Jørgensen.



2013
Pato Collection
Welling/Ludvik

Fredericia launches the Pato series by Welling/Ludvik. The aim is to apply high standards of craftsmanship to a multi-purpose polypropylene chair.



2019
Calmo Collection
Hugo Passos

Fredericia introduces the Calmo Collection by Hugo Passos, bridging Fredericia's sofa heritage with modern application areas in homes, hotels and offices.



1971
Danish Furniture Prize

Mogensen and Graversen jointly receive the Danish Furniture Prize for their collaboration. Mogensen dies prematurely the next year.

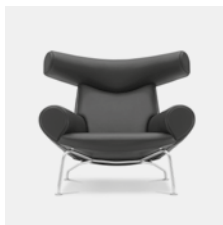

1988
Ox Chair reborn

Wegner updates the internal upholstery of the Ox Chair together with Erik Jørgensen, finally making it possible to achieve a long-lasting internal foam structure.

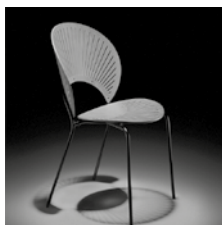

1993
Trinidad
Nanna Ditzel

Nanna Ditzel and Fredericia launch the Trinidad Chair, utilising new CNC technology.



2007
Delphi
Hannes Wettstein

Hannes Wettstein designs the Delphi Sofa, launched by Erik Jørgensen



2016
Pon & Taro
Jasper Morrison

Jasper Morrison designs the Pon, Taro and Kile collections for Fredericia.

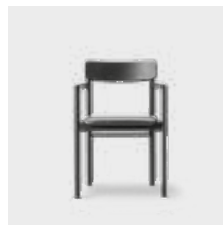

2020
Post Collection
Cecilie Manz

The Post Collection by Cecilie Manz is complete with chair and table, introduced at the Stockholm Furniture Fair.



1975
EJ315 Sofa
Erik Ole Jørgensen

Erik Jørgensen launches the EJ315 Sofa designed by architect Erik Ole Jørgensen.



1998
Gallery Stool: Hans Sandgren Jakobsen

Fredericia launches the Gallery stool by Hans S. Jakobsen, where the properties of moulded plywood are pushed to the limit to form a sculptural seating object.

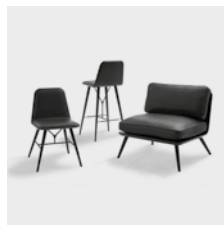

2011
Spine Series
Space Copenhagen

Fredericia launches the Spine Series by Space Copenhagen, which initiates the development of expertise in the hospitality segment.

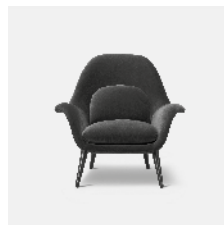

2016
Swoon
Space Copenhagen

Fredericia launches the Swoon Chair by Space Copenhagen, reflecting the shift from single-function lobby furniture towards comfortable, versatile lounge chairs.



2020
The acquisition of Erik Jørgensen

Fredericia acquires Erik Jørgensen Møbelfabrik, extending the company's range of iconic designs and in-house upholstery skills.

1970

1980

1990

2000

2010

2020



We have been inspiring conscious consumption ever since Fredericia was founded in 1911.

Based on designs made from good, honest materials. Chosen for their innate beauty and ability to age with grace.

It's a mindset inspired by our work with Børge Mogensen, who championed the idea of timeless, durable designs that last from one generation to the next.

Long-lasting, well-conceived and crafted ideas that contribute to a sense of wellbeing – and bring an extra dimension to living, working and socialising.

Crafted to last.

Respect for natural materials and the people who will use our furniture is an ethos at the core of our approach to furniture.

At Fredericia, we have a profound passion for materiality, celebrated in countless designs which highlight our choice of materials. Consequently, sustaining the source of raw materials worldwide is crucial for us.

That's why we insist on wood sourced from responsibly-managed forests and high calibre leather from European partners, who comply with the highest standards of animal welfare. Each material we use is kept as pure as possible, able to be refreshed, repurposed or recycled in the future.

Fredericia supports the United Nations' Global Goals for Sustainable Development. Such as promoting the sustainable use of natural materials, responsible consumption and production, as well as sustainably-managed forests and strategies to help reduce any impact on climate change. Furthermore, we have a comprehensive Code of Conduct for our sub-contractors to comply with. To ensure that raw materials are traceable, that harmful factors are minimised in materials and manufacturing, and that everything is handled according to environmental management systems.





Berge Mogensen's former house, located on Solosevej in Gentofte just north of Copenhagen.



Extensive leather expertise

Leather has been used for making furniture for more than 1,000 years. As a natural, durable material, leather creates very long-lasting products. More than anything, leather furniture must be used and lived with in order to attain the most beautiful appearance – it simply gets better with age! As a result, it is our experience that people end up taking better care of leather furniture.

Throughout the years, we have perfected our relationships with leather tanneries so as to offer the finest furniture leather on the market. Denmark used to have a long tradition of high quality tanneries up until the early 1990s, when the last Danish tannery closed. From that point on, the Danish tanning industry consolidated in Italy and, on a smaller scale, in Sweden. All Fredericia leather is tanned in Italy and Sweden, and direct access to tanneries is an important part of our approach to leather sourcing.

We carefully select premium quality leather in order to provide the highest calibre leather for our designs. Genuine leather that will age with grace. Beautiful, high quality leather starts with healthy livestock. All Fredericia leather comes from well-known, certified sources, where professionals are trained to respect animals, while optimising the quality of the raw hides.

Our entire Fredericia Leather collection is comprised of raw hides guaranteed to be sourced from European livestock, primarily from Germany, Sweden and Denmark. For a growing number of articles in our collection, we offer expanded traceability, with the ability to trace the origin of raw hides back to each specific animal.

As part of our approach to recycling and waste management, excess leather from our furniture production is sold off to third parties for producing small leather goods, such as gloves, shoes and boxes. Additionally, a portion of our leather remnants is also donated to local schools for children's workshops. It's a practice that we have had in place at Fredericia for over 30 years.



Upholstery excellence

Our two upholstery workshops in Denmark represent a combined body of upholstery knowledge unparalleled in Scandinavia, where we keep our traditions alive and apply our internal wealth of knowledge. At the same time, we draw on the insights and expertise of our staff to inspire the ongoing evolution of our designs.

The Ox Chair is a perfect example of an innovative approach to an old craft. With its voluminous upper body on a delicate steel base, it was a challenge to produce when it was first launched in the 1960s by the AP Workshop in Copenhagen. In the late 1980s, Hans J. Wegner turned to Erik Jørgensen for his upholstery expertise and the result was quite cutting edge at the time. Together they introduced modern block foam to the chair, making it extremely stable in form over time, as opposed to the traditional method used before. Nevertheless, the process of upholstering the Ox Chair remains a very handcrafted technique. The sculpted lines and organic curves require expert craftsmanship skills and a certain amount of physical strength. It actually takes an entire day to make each Ox Chair.

Our Mogensen 22 Collection represents a parallel combination of traditional craft and modern design. Meticulous attention goes into the joinery to ensure a sturdy, stable construction. The hand-filled cushions. The leather piping detail. Two upholsterers work together to stretch the carefully-stitched leather over hardwood frames, resulting in a glove-like fit that will keep its shape for many years to come. In fact, it takes two trained professionals up to six hours to upholster one sofa.

With two comprehensive Fredericia workshops, we utilise the latest technology in tandem with traditional techniques. Still, it's the dedication of our crafts people who make the difference. Because only a well-made design that serves you well is worth keeping for a long time.

Pay attention to the upholstery. Only fine craftsmanship will provide you with the longevity that you wish for.

Translated from the
1924 Fredericia catalogue





The finest wood



Wood has a warm radiance and an intuitive way of adding a sense of well-being to interiors. It's a remarkable, natural material used for furniture since the first chairs ever recorded in history, in Egypt and China. In many ways, wooden furniture provides a truly long-lasting perspective of use. For example, a raw hardwood table can be sanded down and, to a great extent, renewed and repaired. However, owners of wooden furniture share the responsibility of maintaining their furniture to fulfil a chair's full life potential.

Traceability and replanting

For more than a decade, it has been our policy at Fredericia to work with responsibly-managed forests. Raw hardwoods forested from sources where no more trees are felled than the forest can reproduce naturally. The FSC® Forest Management certification verifies that a forest is being managed in an environmentally-responsible manner. The criteria for certification extends from procedures that preserve biodiversity to making sure that practices benefit the lives of workers and the local community. The FSC® standard is being gradually applied on a product level to our entire range of furniture crafted with wood. This makes it easier for professionals to specify responsibly-produced products with documentation. Fredericia is FSC® certified under the license number FSC® 151292.

Wood is a vital part of the world's ecological circuit

Our wood comes from forests, where oak trees are cultivated for a slow growth, mixed with other tree species which lead to a tight, resilient grain. We believe it is our duty to create only high quality, durable furniture out of respect for the 150 years that it typically takes to grow a single oak tree suitable for furniture production.



FSC Licence number
FSC® 151292

Reflecting our mutual passion for materiality and background in craftsmanship, seen in classic and contemporary designs with a sculptural elegance.



A kindred spirit in Erik Jørgensen



In October 2020, Fredericia acquired the Danish furniture manufacturer Erik Jørgensen. A company with a long, renowned history of Danish design, with an approach to quality and craftsmanship that goes hand in hand with our own.

Erik Jørgensen was founded in 1954 by saddler and designer Erik Jørgensen. During the 1970s, the company was considered a frontrunner in Danish furniture design. Jørgensen earned a reputation for his remarkable upholstery skills, inventive upholstered furniture and unsurpassed expertise in Scandinavia with sofas.

The Ox Chair by Hans J. Wegner is a prime example. Originally launched in 1960, it only remained in production for a limited number of years due to the extremely demanding construction. In the late 1980s, Wegner reached out to Jørgensen, who rose to the occasion with an inventive solution. This led to the Ox Chair's relaunch in 1988 with unprecedented success.

With Fredericia's acquisition of Erik Jørgensen, the outcome is one company with combined areas of expertise from both. Reflecting our mutual passion for materiality and background in craftsmanship, seen in classic and contemporary designs with a sculptural elegance.

As one company under the Fredericia name, we have an exceptional combined knowledge of upholstery with incomparable insights and experience with sofa design. Together with our comprehensive in-house production and our workshops in Fredericia and Svendborg, it all contributes to our ability to innovate - and expand on our legacy of originality.

Fredericia ERIKJØRGENSEN

Collection

Chairs & Stools

BM61 Chair & BM62 Armchair	72
Eyes	110
Flamingo Chair	94
J39 Mogensen Chair	30
J64 Chair & J63 Stool	58
Lynderup Chair	44
Mogensen Bench & 3236 Chair	62
Pato Executive	132
Pato Sledge	136
Pato Swivel & Pato Office	128
Pato Wood Base	126
Pato 4 Leg	118
Plan Chair	38
Post Chair	52
The Spanish Dining Chair	68
Spine	102
Swoon Chair	96
Søborg Chair	78
Trinidad Chair	88
Yksi Chair	84

Lounge Chairs

The A-Chair	204
Calmo Chair & Calmo Ottoman	222
The Canvas Chair	158
Corona Chair & Corona Ottoman	198
Ditzel Lounge Chair	194
Eyes Lounge	218
The Hunting Chair	150
Mogensen 2334 Lounge Chair	156
Mono Pouf	224
Pato Lounge	214
Savannah Chair	208
Savannah Petit	212
The Spanish Chair	144
Spine Lounge Chair	190
Swoon Lounge Petit	186
Swoon Lounge & Swoon Ottoman	178
Wegner Ox Chair	164
Wegner Queen Chair	170
Wegner J16 Rocking Chair & Stool	172
Wegner 1788 Easy Chair	176
2207 Chair, 2204 Wing Chair & 2202 Ottoman	152

Sofas

Calmo Sofa	270
Delphi Elements	242
Delphi Sofa	240
EJ220 Elements	300
EJ220 Sofa	298
EJ280 Elements	290
EJ280 Sofa	284
EJ288 Sofa	292
EJ295 Chaise Sofa	296
EJ315 Sofa	252
Haiku Sofa	280
JG Sofa	264
Konami Sofa	276
Mogensen Coupé Sofa	236
Mogensen 2208 & 2209 Sofa	234
Mogensen 2212 & 2213 Sofa	230
Mogensen 2335 & 2333 Sofa	238
No.1 Sofa	262
Savannah Sofa	268
Spine Lounge Sofa & Daybed	248
The Spoke-Back Sofa	258

Coffee Tables

EJ66 Coffee Table	364
Insula Table	348
Islets Table	354
Pal Table	352
Piloti Alu Table	360
Piloti Stone Table	358
Piloti Table	356
Pon Table	346
Tableau Coffee Table	362
Wegner Ox Table	366

Complements

Fellow Lamp	376
Gallery Stool	390
Hydro Vase	378
JG Folding Stool	386
Locus Bowl	380
Magazine Table	392
Meadow Lamp	374
Nara Coat Stand	388
Sequoia Pouf	384
Silhouette Mirror	382

Tables

Ana Table	334
BM71 Library Table	306
C18 Table	308
Islets Dining Table	316
JG Table	322
Plan Table	318
Mesa Table	338
Post Table	330
Taro Table	326
6284 Table	310
6286 & 6386 Table	312

Chairs & Stools

Essentially, a chair must take into consideration human behaviour and the psychology of space. It should visually enhance an interior – and the wellbeing of the people there to enjoy it. Chairs are one of the primary areas of our expertise. They are also indispensable objects that are fundamental to how we live and work.

J39 Mogensen Chair	30
Plan Chair	38
Lynderup Chair	44
Post Chair	52
J64 Chair & J63 Stool	58
Mogensen Bench & 3236 Chair	62
The Spanish Dining Chair	68
BM61 Chair & BM62 Armchair	72
Søborg Chair	78
Yksi Chair	84
Trinidad Chair	88
Flamingo Chair	94
Swoon Chair	96
Spine	102
Eyes	110
Pato 4 Leg	118
Pato Wood Base	126
Pato Swivel & Pato Office	128
Pato Executive	132
Pato Sledge	136

A masterpiece in solid wood

While the J39 Mogensen Chair is reminiscent of Mediterranean, Scandinavian and Shaker furniture, its simple expression and use of materials reflect Mogensen's personal quest for design purity. The sturdy yet refined appeal the J39 Chair makes it suitable for private and public use.

To this day, both new and vintage versions of the chair can be seen in public institutions, universities, cafés, restaurants and private homes in Denmark and around the world. Given its versatility and appeal to virtually anyone in any environment, the J39 Chair has been in continuous production since its introduction in 1947.



Borge Mogensen, 1947

Model 3239
Chair
W 48,5 D 42,5 H 77 cm
SH 46,5 cm

Wood:
Beech soap, Oak soap, Oak oil, Oak light oil, Oak black lacquered, Walnut oil, Beech black lacquered, Beech white painted, Khaki green, Vintage lacquered, Pebble grey.

Seat:
Natural paper cord
Black chair available with black paper cord

PRODUCT SHEET DOWNLOAD
[FREDERICIA.COM](https://www.fredericia.com)

J39 Mogensen Chair

J39 Chair
Wood: Oak oil
Seat: Natural paper cord





Björk Brasserie, Milano





J39 Chair. Wood: Oak soap. Seat: Natural paper cord.





J39 Chair. Wood: Khaki green. Seat: Natural paper cord
C18 Table. Wood: Oak soap.



J39 Chair. Wood: Oak black lacquered. Seat: Natural paper cord

A chair with a minimal footprint

With its surprisingly minimal footprint and generous comfort, the Plan Chair is ideal for modern spaces that invite a variety of uses, from extensive hospitality and office applications to everyday living.

While sturdy and tested for extreme public use, each component of the Plan Chair is prepared for end-of-use disassembly and ease of possible future reparations - designed to last in a circular economy. Plan Chair successfully balances industrial elements and soft humanistic curves with its materiality, tactility, and crafted details.



Edward Barber & Jay Osgerby, 2022

Model 3414
Chair
W 42 D 52 H 77 cm
SH 46 cm

Model 3413
Chair
W 42 D 53 H 77 cm
SH 46 cm

Model 3412
Chair
W 42 D 52 H 77 cm
SH 45 cm

Wood:
Oak lacquered, Black ash.

Steel:
Black, Modernist Green, Bordeaux.

Upholstery:
Leather or fabric.

Wood:
Oak lacquered, Black ash.

Steel:
Black, Modernist Green, Bordeaux.

Upholstery:
Leather or fabric.

Wood:
Oak lacquered, Black ash.

Steel:
Black, Modernist Green, Bordeaux.

Upholstery:
Leather or fabric.

PRODUCT SHEET DOWNLOAD
FREDERICIA.COM

Plan Chair

Plan Chair
Wood: Oak lacquered
Steel: Black





Björk Brasserie, Milano





Plan Chair. Seat and back: Black ash. Steel: Black.



Stackable & adaptable

The Lynderup Chair connects the past to the present with a promising future. Designed by Børge Mogensen in 1954, it has a light appearance that can accommodate a variety of purposes and settings. The chair is also physically light and able to be stacked. With its simple, straight-forward design, functional approach and durable construction, the Lynderup Chair is a practical solution for conference rooms, commercial spaces, work environments and more.



Børge Mogensen, 1954

Model 3080
Chair
W 54 D 50 H 77 cm
SH 46 cm

Model 3081
Chair, seat upholstered
W 54 D 50 H 77 cm
SH 47 cm

Wood:
Oak lacquered, Black lacquered,
Walnut lacquered, Deep red.

Base:
Black, Chrome.

Wood:
Oak lacquered, Black lacquered,
Walnut lacquered, Deep red.

Base:
Black, Chrome.

Upholstery:
Leather or fabric

PRODUCT SHEET DOWNLOAD
FREDERICIA.COM

Lynderup Chair

Lynderup Chair
Wood: Black lacquered
Base: Black



Lynderup Chair. Wood: Black lacquered. Base: Black
Taro Table. Wood: Oak light oil.
Hydro Vase







Lynderup Chair. Shell: Oak lacquered. Base: Black.



Lynderup Chair, Shell: Black, Base: Black
Pato 4 Leg Barstool Upholstery: Leather Max 92 Tan, Base: Chrome.
Hydro Vase





The innate beauty of wood

Simplicity imbued with a sense of beauty is at the core of the Post Collection from Cecilie Manz. Clear, clean lines are the signature traits of the Post Chair, boasting a solid wood frame that reflects our heritage of wood craftsmanship and appreciation for authentic materials.

The Post Chair is upright and unassuming with a light yet sturdy plywood seat and back. Featuring arms that offer just enough support with a minimal use of space. Add to that the option of an upholstered seat in leather or fabric, and you have a subtle design that could easily fit into a residential setting, restaurant, café or corporate environment.

Cecilie Manz, 2019



Model 3445
Armchair
W 54 D 49,5 H 79,5 cm
SH 45 cm



Model 3446
Armchair, seat upholstered
W 54 D 49,5 H 79,5 cm
SH 46,5 cm

Wood:
Oak lacquered, Oak light oil,
Black lacquered.

Wood:
Oak lacquered, Oak light oil,
Black lacquered.

Upholstery:
Leather or fabric

PRODUCT SHEET DOWNLOAD
FREDERICIA.COM

Post Chair

Post Chair
Upholstery: Leather Omni 301 Black
Wood: Black lacquered

Taro Table
Wood: Oak oil







Post Chair. Upholstery: Leather Omni 301 Black. Wood: Oak black lacquered.

Post Chair. Upholstery: Leather Omni 377 Dark Brown. Wood: Oak light oil.
Post Table. Wood: Oak light oil.
Locus Bowl





Post Chair. Wood: Oak lacquered
Post Table. Wood: Oak soap

Post Chair. Wood: Oak lacquered
Post Table. Wood: Oak soap

Nordic folk & Windsor

There is one designer whose work is more well-known than his name, Eivind A. Johansson. His ambition was to create modest, well-made, everyday furniture appreciated for its purity in form and function. An approach instantly apparent in the J64 Chair designed in 1957, which references Nordic folk and traditional Windsor furniture.

The signature spoke-back and gentle, sloping armrests make this a timeless classic. At the same time, the curve of the seat and back add ergonomic comfort, as well as a strong graphic expression. The J64 is ideal as a dining chair or as a lightweight easy chair, accompanied by a cushion or blanket.

The J63 Stool echoes a similar bare simplicity, with a focus on the functional and the practical. Clearly evident the J63's curved seat and simple, supportive frame. It's the kind of design you would welcome as an occasional seat for guests, a small stool in a kitchen, by a bedside or as a decorative detail in a living room.



Eivind A. Johansson, 1957

Model 3064
Armchair
W 59,5 D 54 H 79,5 cm
SH 45 cm

Model 3063
Stool
W 48 D 34,5 H 47 cm
SH 42,5 cm

Wood:
Ash black lacquered,
Ash white painted.

Wood:
Ash black lacquered

PRODUCT SHEET DOWNLOAD
FREDERICIA.COM

J64 Chair & J63 Stool

J64 Chair
Wood: Black ash





J64 Chair. Wood: Black ash.
Taro Table. Wood: Smoked oak oil.



J63 Stool. Wood: Black ash.

Refined yet rustic

In 1955, Borge Mogense designed an entirely new furniture collection for Fredericia. One of the earliest outcomes was the launch of the 3236 Chair and Bench in 1956. With its solid, simplified construction, the design reflects Mogensen's preference for working with refined yet rustic, natural materials. Along with his eye for perfect proportions.

The robust dimensions of the chair make this a stable, sturdy design, allowing for hours of sitting. Adding to the comfort is the upholstered seat characterised by a simple curve, capturing another signature trait of Mogensen. To never lose sight of a design's original intent and functional purpose, while avoiding any unnecessary elements. The result is a classic chair ideal as a side chair. Simple, modest and still self-confident, just like its creator.



Borge Mogensen, 1956

Model 3171
Bench
D 48,5 H 77 L 171,5 cm
SH 46 cm

Model 3236
Chair
W 53 D 46,5 H 75 cm
SH 46 cm

Wood:
Oak soap, Oak light oil, Oak black
lacquered, Smoked oak oil.

Upholstery:
Leather or fabric

Wood:
Oak soap, Oak black lacquered.

Upholstery:
Leather or fabric

PRODUCT SHEET DOWNLOAD
FREDERICIA.COM

Mogensen Bench & 3236 Chair

Mogensen 3236 Chair
Upholstery: Leather Vegeta 90 Natural
Wood: Oak soap







3171 Bench. Upholstery: Leather Vegeta 90 Natural. Wood: Oak light oil.

Mogensen Bench. Upholstery: Leather Vegeta 90 Natural. Wood: Oak light oil.

3236 Chair. Upholstery: Leather Omni 301 Black. Wood: Oak black lacquered.
Taro Table. Wood: Oak light oil.





A material statement

With its Danish accent on functionally-driven design, durability and simple, declarative style, the Spanish Dining Chair is a modern classic that's easy to envision in hotels, restaurants, homes and countless other settings around the globe.



Model 2226
Lounge Chair
Page 144



Model 3237
Chair
W 56 D 48 H 84,5 cm
SH 46 cm



Model 3238
Armchair
W 64,5 D 48 H 84,5 cm
SH 46 cm

Borge Mogensen, 1964

Wood:
Oak soap, Oak light oil, Oak oil,
Smoked oak oil, Oak black lacquered.

Leather:
Natural or Cognac with brass buckles
Black with chrome buckles

Wood:
Oak soap, Oak light oil, Oak oil,
Smoked oak oil, Oak black lacquered.

Leather:
Natural or Cognac with brass buckles
Black with chrome buckles

PRODUCT SHEET DOWNLOAD
FREDERICIA.COM

The Spanish Dining Chair

The Spanish Dining Chair
Upholstery: Natural saddle leather
Wood: Oak soap





The Spanish Dining Chair. Upholstery: Natural saddle leather. Wood: Oak soap.
Post Table. Wood: Oak soap.
Locus bowl



Only what's crucial to the construction

Slender yet solid, simple yet striking, the BM61 Chair and BM62 Armchair bring us back to nature in a welcome return to classic shapes that capture essence of a concept. Exposed construction. And authentic materials that outlast any temporary trend. Both versions of the chair are a true tribute to our company credo: to create modern originals crafted to last.

For their author, Borge Mogensen, a long-lasting design starts with clean lines, involving only what's crucial to the construction. Coupled with time-honoured craftsmanship skills to ensure the purity of each line. What's more, honest materials add character without compromise. In a design that will age with beauty and dignity.



Borge Mogensen, 1957

Model 3361
Chair, linen webbing
W 48 D 49,5 H 76,5 cm
SH 45,5 cm

Model 3362
Armchair, linen webbing
W 60 D 49,5 H 76,5 cm
SH 45,5 cm

Model 3261
Chair, cane wicker
W 48 D 49,5 H 76,5 cm
SH 45,5 cm

Model 3262
Armchair, cane wicker
W 60 D 49,5 H 76,5 cm
SH 45,5 cm

Wood:
Oak lacquered, Oak oil,
Oak black lacquered.

Webbing:
Natural linen
Black chair available with black linen

Wood:
Oak lacquered, Oak oil,
Oak black lacquered.

Webbing:
Natural linen
Black chair available with black linen

Wood:
Oak lacquered, Oak oil.

Webbing:
Natural cane wicker

Wood:
Oak lacquered, Oak oil

Webbing:
Natural cane wicker

PRODUCT SHEET DOWNLOAD
FREDERICIA.COM

BM61 Chair & BM62 Armchair

BM61 Chair
Wood: Oak black lacquered
Seat/back: Linen webbing natural





BM61 Chair. Wood: Oak oil. Seat and back: Natural cane wicker.
Taro Table. Wood: Oak light oil.

BM62 Chair. Seat and back: Linen webbing natural. Wood: Oak lacquered.
6386 Table. Wood: Oak soap.







BM61 Chair. Seat and back; Linen webbing natural. Wood: Oak lacquered.
Library Table. Wood: Oak oil.

BM62 Chair. Seat and back; Cane wicker. Wood: Oak oil.
6386 Table. Wood: Oak soap.

A handcrafted approach to an industrial dilemma

In 1950, Børge Mogensen introduced the prototype of the Søborg Chair. His fusion of functionalism, expertise in cabinetmaking and use of new production techniques led to a remarkably simple chair that could be manufactured industrially.

Merging his signature love of solid wood with his new-found passion for plywood shells, Mogensen crafted the Søborg Chair with soft rounded corners and gentle lines in a timeless design that appears light yet solid, with an ample-sized seat and back to ensure endless hours of comfort.

It is a handcrafted approach to an industrial dilemma that highlights the textural properties of solid wood, plywood and later steel, in a subsequent version for the frame.

The Søborg Chair remains a favourite for its simple, unimposing presence. A chair that's equally at home in any modern environment.



Børge Mogensen, 1950

Model 3050
Without upholstery
Model 3051
Seat upholstered
Model 3052
Fully upholstered
Chair, Wood Base
W 51 D 48,5 H 80 cm
SH 45,5 cm

Model 3060
Without upholstery
Model 3061
Seat upholstered
Model 3062
Fully upholstered
Chair, Metal Base
W 50,5 D 50 H 78 cm
SH 44 cm

Wood:
Oak lacquered, Oak oil, Black
lacquered, Walnut lacquered.

Upholstery:
Leather or fabric

Wood:
Oak lacquered, Oak oil, Black
lacquered, Walnut lacquered.

Metal base:
Black, Chrome.

Upholstery:
Leather or fabric

PRODUCT SHEET DOWNLOAD
FREDERICIA.COM

Measurements are based on models without upholstery.
Measurements may vary between 0,5-1,5 cm when upholstered

Søborg Chair

Saborg Chair
Wood: Oak black lacquered
Upholstery: Leather Omni 301 Black
Taro Table
Wood: Smoked oak





Seborg Chair. Wood: Oak black lacquered. Upholstery: Leather Omni 301 Black.



Saborg Chair. Upholstery: Remix 233. Wood: Oak lacquered.
Sequola Pouf. Upholstery: Wool.





Crafted, compact and versatile

Yksi means "one" in Finnish, reflecting several elements incorporated into a singular design, signalling classic elegance with a modern twist. The Yksi Chair has two pairs of legs that unite in an upside-down Y-shaped base, as a focal point of support for the seat. The distinctive shape crafted in solid oak is a contemporary take on classic woodworking techniques aimed at a modern audience.

Designed by Thau & Kallio, the structure makes the chair surprisingly light – both visually and in terms of weight. Two chairs can be stacked for compact storage, adding extra appeal for professional work spaces, corporate dining halls, cafés and private kitchens.



Thau & Kallio, 2018

Model 3340
Armchair
W 54,5 D 49 H 76 cm
SH 46 cm

Model 3341
Armchair, seat upholstered
W 54,5 D 49 H 76 cm
SH 47 cm

Wood:
Oak lacquered, Oak black lacquered.

Wood:
Oak lacquered, Oak black lacquered.

Upholstery:
Leather or fabric

PRODUCT SHEET DOWNLOAD
FREDERICIA.COM

Yksi Chair

Yksi Chair
Upholstery: Leather Omni 307 Cognac
Wood: Oak lacquered.

Pato Table
Table top: White Carrara
Base: Chrome



Yksi Chair. Wood: Oak black lacquered.
Taro Table. Wood: Oak light oil.





A post-modern milestone

When designing the Trinidad Chair in 1993, Nanna Ditzel found inspiration in the elaborate fretwork from the Gingerbread Facades that she had seen in the colonial architecture while travelling through Trinidad. Much like the facades, the cut-out fretwork of the chair triggers an interplay of light and shadows, creating a pattern projected into space and a subtle sense of motion.

With the Trinidad Chair, instead of eliminating any ornamentation, which was part of the Modernist mantra, Ditzel did the opposite. She kept the ornamentation as the focal point in a distinctive chair that challenged the prevailing design dogma at the time.

The cut-outs featured in the curved shell not only function as a decorative element, they also dramatically lighten the visual density of the chair. A process involving the most advanced CNC technology at the time and techniques normally impossible in plywood shell furniture.

In fact, when the chair was first introduced, it was heralded as a breakthrough in design technology. What's more, the lightweight design allows for hours of seating comfort, able to suit any setting as well the person who sits in it. The fretwork ensures that the body is always ventilated and the chair is always kept at room temperature. At the same time, it provides excellent acoustics where sound resonance should be reduced.



Nanna Ditzel, 1993/1998

Model 3398
Without upholstery
Model 3396
Seat upholstered
Chair
W 48,5 D 57 H 85 cm
SH 45,5 cm

Model 3399
Without upholstery
Model 3397
Seat upholstered
Armchair
W 61 D 57 H 85 cm
SH 45,5 cm

Model 3400
Without upholstery
Model 3401
Seat upholstered
Barstool
W 45 D 50 H 112,5 cm
SH 77 cm

Wood:
Beech lacquered, Oak lacquered,
Walnut lacquered, Smoked oak
stained, Grey oak stained, Light grey
oak stained, Black ash.

Base:
Black, Flint, Chrome.

Upholstery:
Leather or fabric

Wood:
Beech lacquered, Oak lacquered,
Walnut lacquered, Smoked oak
stained, Grey oak stained, Light grey
oak stained, Black ash.

Base:
Black, Flint, Chrome.

Upholstery:
Leather or fabric

Wood:
Beech lacquered, Oak lacquered,
Walnut lacquered, Smoked oak
stained, Grey oak stained, Light grey
oak stained, Black ash.

Base:
Black, Flint, Chrome.

Upholstery:
Leather or fabric

PRODUCT SHEET DOWNLOAD
FREDERICIA.COM

Measurements are based on models without upholstery. Measurements may vary between 0,5-1,5 cm when upholstered

Trinidad Chair

Trinidad
Wood: Grey oak stained
Base: Flint

Islets Table
Wood: Oak light oil

Silhouette Mirror
Wood: Walnut oil





The fretwork provides excellent acoustics where sound resonance should be reduced.
Royal Danish Academy of Music,
Copenhagen



Trinidad. Wood: Grey oak stained,
Light grey oak stained. Base: Flint.



Trinidad. Wood: Grey oak stained. Base: Flint.



Graceful & graphic

Almost like a flamingo standing on its slender legs, the Flamingo Chair is at once aesthetic and poetic. The graceful curves of the seat with its symbolic "wings" for arms are poised above the steel frame and long, slim legs. While the back appears as if it's floating on top. It all culminates in an exquisite expression of fluid lines.

Flamingo is a neo-classic from 2003, with an appeal that's timeless and trendless. The steel legs bring a subtle graphic contrast to the soft, organic shape of the chair.

In a distinctive silhouette that's attractive from any angle. Flamingo adds elegance to dining experiences and a sense of tranquillity to executive meeting rooms. In a private setting, it makes for a stunning side chair or a stylish choice for a home office. It's equally as appealing in a hotel lobby, opera house or cultural centre as a sculptural statement piece.



Johannes Foersom &
Peter Hiort-Lorenzen, 2003

Model 3380
Chair, X-base fixed
W 68 D 63 H 80 cm
SH 45 cm

Model 3381
Swivel Chair, X-base
W 68 D 63 H 80 cm
SH 45 cm

Base:
Brushed stainless steel, Black.

Upholstery:
Leather or fabric

Base:
Brushed stainless steel, Black.

Upholstery:
Leather or fabric

PRODUCT SHEET DOWNLOAD
[FREDERICIA.COM](https://www.fredericia.com)

Flamingo Chair

Flamingo Chair
Upholstery: Leather Primo 75 Cognac
Base: Brushed stainless steel

Taro Table
Wood: Smoked oak

Hydro Vase



A sculptural silhouette

Soft, organic lines. A sculptural silhouette. An elegant design that invites you to come closer. Encouraging you to live life at a slower pace. Those are just some of the intentions behind the Swoon Chair by Space Copenhagen. Reflecting their intuitive approach to design, which is inspired by circumstances and the human condition.

Drawing on their impressive projects in the hotel and hospitality sector, they were keen on a sophisticated look that would lend itself to hours of comfort. Their initial outcome was the Swoon Lounge, which was designed for the 11 Howard Hotel in New York.

Space Copenhagen, 2016/19



Model 1777
Armchair, Wood base
W 62 D 63 H 86 cm
SH 46 cm



Model 1779
Swivel Armchair, X-base
W 62 D 63 H 86 cm
SH 46 cm

Wood:
Oak lacquered, Walnut lacquered,
Smoked oak stained, Black lacquered.

Upholstery:
Leather or fabric

Metal Base:
Black, Polished aluminium

Upholstery:
Leather or fabric

PRODUCT SHEET DOWNLOAD
FREDERICIA.COM

Swoon Chair

Swoon Chair Wood Base
Upholstery: Clay 17
Wood: Oak lacquered

Post Table
Wood: Oak light oil



Swoon Swivel Chair
Upholstery: Clay 13. Base: Polished aluminium.
BM71 Library Table. Wood: Oak oil.
Sequoia Pouf. Upholstery: Wool.



Swoon Chair Wood Base. Upholstery: Clay 13 Wood: Oak lacquered.





Swoon Swivel Chair. Upholstery: Clay 12. Base: Polished aluminium.
Taro Table. Wood: Oak oil.
Hydro Vase.



Subtle strength of character

Spine boasts strong lines balanced by subtle curves. Contrasts that merge into a singular entity. In a design that's solid and graphic yet soft and organic. Anchored in Nordic tradition with a twist that gives it a striking, fresh aesthetic.

The Spine series has expanded since its initial launch to encompass a variety of products and a growing number of variants, found in deluxe restaurants, bars, hotels and exclusive retail shops worldwide. Adding a touch of tension and dimension is the interplay between the upholstery and the base, available in either wood or metal.

Spine in wood is classic and luxurious, exuding a certain strength of character. Whereas the sleekness of the metal base signals a look that's modern and light. The upholstery is inspired by techniques that were developed at our Fredericia workshop for Børge Mogensen's exclusive 1960's leather series. With its graceful appearance, Spine is all about contrasting elements that culminate in a cohesive concept that's inviting wherever you place it.



Space Copenhagen,
2011–18

Model 1721
Chair, Wood base,
front upholstered
W 46,5 D 54,5 H 76 cm
SH 46,5 cm

Model 1736
Stool, Wood base,
seat upholstered
W 42,5 D 35 H 68/74 cm

Model 1731
Barstool, Wood base,
front upholstered
W 45 D 51,5 H 98/104 cm
SH 68/74 cm

Model 1936
Stool, Metal base,
fully upholstered
W 42,5 D 35 H 68/74 cm

Model 1931
Barstool, Metal base,
fully upholstered
W 45 D 53,5 H 97,5/104 cm
SH 69,5/74 cm

Wood:
Oak lacquered, Black lacquered,
Smoked oak stained.

Metal parts:
Black

Upholstery:
Leather or fabric

Wood:
Oak lacquered, Black lacquered,
Smoked oak stained.

Metal parts:
Black

Upholstery:
Leather or fabric

Wood:
Oak lacquered, Black lacquered,
Smoked oak stained.

Metal parts:
Black

Upholstery:
Leather or fabric

Metal Base:
Black

Upholstery:
Leather or fabric

Metal Base:
Black

Upholstery:
Leather or fabric

PRODUCT SHEET DOWNLOAD
FREDERICIA.COM

Spine



Spine Wood Base Barstool and
Spine Wood Base Stool
Upholstery: Leather Primo 88 Black
Wood: Oak black lacquered



Spine Wood Barstool. Upholstery: Leather Primo 88 Black. Base: Oak black lacquered.





Spine Chair. Upholstery: Leather Primo 88 Black.

Spine Chair. Upholstery: Leather Primo 88 Black.
Base: Oak black laquered.







Spine Metal Base Stool. Upholstery: Hallingdal 224. Base: Black.

The eyes of the beholder

Eyes is an endearing design that can enliven any interior. The soft organic shape is like a welcoming gesture, inviting you to sit down and stay awhile. Eyes is a versatile series of chairs that you can truly personalise. Choose from a variety of different bases and an extensive array of fabrics, leather and colours for matching any interior. Allowing you to create the perfect chair in the eyes of the beholder.

The seat is a fully-upholstered shell of moulded, cold-cured foam guaranteeing a high level of comfort for hours. Pair the chair with wooden legs, a cantilever, swivel or tube base, and you have an attractive, comfortable chair for corporate meetings, dining at a restaurant, as side chairs in a lobby or living room.

The Eyes Barstool exemplifies a functionally-driven design where the form is all about comfort, with a touch of charisma. Seen in a softly curved shell that's engineered for leaning back with ease for hours on end. The slim, steel legs add a graphic element that gives the chair a light, airy feeling. Together with the shell the effect is understated and elegant.



Johannes Foersom &
Peter Hiort-Lorenzen,
2007/2011

Model 4820
Swivel Armchair, X-base
W 53 D 59 H 84 cm
SH 45 cm

Model 4818
Swivel Chair, X-base
W 53 D 59 H 84 cm
SH 45 cm

Model 4808
Cantilever Armchair
W 53 D 59 H 84 cm
SH 45 cm

Model 4810
4 Leg Chair
W 53 D 59 H 84 cm
SH 45 cm

Model 4830
4 Leg Barstool
W 51 D 63 H 104/114 cm
SH 65/75cm

Base:
Black, Polished aluminium.

Armrest:
Leather Vegeta 90 natural, Max 95
cognac or Max 98 black.

Upholstery:
Leather or fabric

Base:
Black, Polished aluminium.

Upholstery:
Leather or fabric

Base:
Black, Brushed stainless steel.

Armrest:
Leather Vegeta 90 natural, Max 95
cognac or Max 98 black.

Upholstery:
Leather or fabric

Base:
Black, Brushed chrome.

Upholstery:
Leather or fabric

Base:
Black, Brushed chrome.

Upholstery:
Leather or fabric

PRODUCT SHEET DOWNLOAD
FREDERICIA.COM

Eyes

Eyes 4-Leg Chair
Upholstery: Gentle 173
Base: Black

Taro Table
Wood: Smoked oak

Locus Bowl











Eyes 4-Leg Barstool. Upholstery: Re-wool 358. Base: Brushed chrome. Meadow Lamp.

Eyes 4-Leg Chair. Upholstery: Gentle 373. Base: Black.
Islets Table: Wood: Oak light oil.
Locus Bowl





100% recycled & recyclable

With Pato, we've applied our legacy of craftsmanship and detailing together with cutting-edge technology to produce an extremely versatile, multi-purpose chair for a variety of applications. Designed by Welling/Ludvik, it's based on the desire to create the simplest chair offering the most comfort possible.

The Pato 4 Leg Chair is made with a 100% recycled and recyclable polypropylene (PP) shell. A material offering the right amount of flexibility in the back. Extra comfort is achieved by the faceted edge, which adds sharpness. Available in countless colours, it can easily accommodate large-scale interiors, a co-working scenario, restaurants and cafés.



Welling/Ludvik,
2013/2016/2019

4 Leg Chair, Stackable
Model 4200
Without upholstery
Model 4201
Seat upholstered
Model 4202
Fully upholstered
W 55 D 52 H 79 cm
SH 46,5 cm

4 Leg Armchair, stackable
Model 4210
Without upholstery
Model 4211
Seat upholstered
Model 4212
Fully upholstered
W 57 D 52 H 79 cm
SH 46,5 cm

4 Leg Center Chair
Model 4250
Without upholstery
Model 4251
Seat upholstered
Model 4252
Fully upholstered
W 45 D 51,5 H 79 cm
SH 46,5 cm

4 Leg Center Barstool
Model 4305
Without upholstery
Model 4306
Seat upholstered
Model 4307
Fully upholstered
W 45,5 D 51 H 99/109 cm
SH 65,5/75,5 cm

4 Leg Center Stool
Model 4315
Without upholstery
Model 4316
Seat upholstered
Model 4317
Fully upholstered
W 49,5 D 46,5
H 83,5/93,5 cm
SH 68/78 cm

Shell:
10 standard colours

Base:
Black, Chrome.

Upholstery:
Leather or fabric

Shell:
10 standard colours

Base:
Black, Chrome.

Armrests:
Black aluminium
Upholstery:
Leather or fabric

Shell:
10 standard colours

Base:
Black, Chrome.

Upholstery:
Leather or fabric

Shell:
10 standard colours

Base:
Black, Chrome.

Upholstery:
Leather or fabric

Shell:
10 standard colours

Base:
Black, Chrome.

Upholstery:
Leather or fabric

PRODUCT SHEET DOWNLOAD
FREDERICIA.COM

Measurements are based on models without upholstery. Measurements may vary between 0,5-1,5 cm when upholstered

Pato 4 Leg

Pato 4-Leg
Shell: Quartz grey
Base: Quartz grey

Pato 4-Leg
Upholstery: Rime 791
Base: Black

Pato 4-Leg
Upholstery: Nubuck 512 Olive
Base: Black painted

Pato 4-Leg
Shell: Storm
Base: Black painted





Pato 4-Leg, Shell: Black. Base: Black.



Pato 4-Leg Armchair. Base: Chrome.







Atelier the Vijzel,
Amsterdam



Human-centric

The Pato Wood Base is living proof that good design has the ability to be interesting, even when reduced to its simplest form. It's a human-centric design comprised of a gentle curved shell that acts as a supportive seat and back. The wooden legs radiate a warm atmosphere while providing a sturdy base.

Adding to its versatility is the choice of eco-friendly polypropylene for the shell in a variety of contemporary colours conducive to virtually any interior. Choose from an array of fabrics and add a textural dimension with subtle tonalities.



Welling/Ludvik, 2016

Chair, Wood base
Model 4225
Without upholstery
Model 4226
Seat upholstered
Model 4222
Fully upholstered
W 45 D 53 H 77,5 cm
SH 46,5 cm

Shell:
10 standard colours

Base:
Oak lacquered, Oak black lacquered.

Upholstery:
Leather or fabric

PRODUCT SHEET DOWNLOAD
FREDERICIA.COM

Measurements are based on models without upholstery. Measurements may vary between 0,5-1,5 cm when upholstered

Pato Wood Base

Pato Wood Base
Upholstery: Leather Max 96 Dark Brown
Wood: Stained oak



Comfort & convenience

Given the changing pace of work and the variety of places we call work, Pato is an attractive solution with numerous versions and advantages. The Pato Office Chair boasts a curved shell ergonomically designed to facilitate efficiency and productivity. Fitted with a 5-point star swivel base on casters, it's a mobile chair that can easily move with you. Adding even more comfort and convenience is a height-adjustable lift and tilt function for task seating.

The Pato Swivel has a similar shell, featuring a 4-point swivel base with optional casters, making it ideal for specific tasks, as well as conference rooms. Both chairs come in a spectrum of specially selected shades for the basic polypropylene version. For a more corporate look, there's the upholstered version with a vast range of fabrics and shades to matching any décor.



Welling/Ludvik, 2014

Swivel Chair, X-base
Model 4000
Without upholstery
Model 4001
Seat upholstered
Model 4002
Fully upholstered
W 63 D 50 H 79 cm
SH 45,5 cm

Swivel Armchair, X-base
Model 4010
Without upholstery
Model 4011
Seat upholstered
Model 4012
Fully upholstered
W 63 D 50 H 79 cm
SH 45,5 cm

Office Chair
Model 4020
Without upholstery
Model 4021
Seat upholstered
Model 4022
Fully upholstered
W 69 D 62,5 H 77-89 cm
SH 43-55 cm

Office Armchair
Model 4030
Without upholstery
Model 4031
Seat upholstered
Model 4032
Fully upholstered
W 69 D 62,5 H 77-89 cm
SH 43-55 cm

Shell:
12 standard colours

Base:
Black, Polished aluminium.

Upholstery:
Leather or fabric

Shell:
12 standard colours

Base:
Black, Polished aluminium.

Armrests:
Black aluminium

Upholstery:
Leather or fabric

Shell:
12 standard colours

Base:
Black, Polished aluminium.

Upholstery:
Leather or fabric

Shell:
12 standard colours

Base:
Black, Polished aluminium.

Armrests:
Black aluminium

Upholstery:
Leather or fabric

PRODUCT SHEET DOWNLOAD
FREDERICIA.COM

Measurements are based on models without upholstery. Measurements may vary between 0,5-1,5 cm when upholstered

Pato Swivel & Pato Office

Pato Office Armchair
Upholstery: Capture 5501
Base: Black

Mesa Table
Table Top: Black linoleum
Base: Black



Pato Office
Upholstery: Leather Max 93 Indian Red
Base: Polished aluminium

Mesa Table
Table Top: Black inoleum
Base: Black





Every detail has a purpose

Pure, simple lines form the basis of Pato, a design where everything superfluous is eliminated and every detail has a function. For Pato Executive, we've enhanced the look to have a touch more impact, with a higher back and arms that emerge from the base as discrete lines.

Choose from our selection of fabrics or premium leather to pair with the 4-point swivel base, in either polished aluminium or black painted steel. From conferences, meeting rooms, banks or law firms to home offices, the Pato Executive makes a singular design statement with character.

Welling/Ludvik, 2015



Model 4052
Swivel Armchair, X-base
W 63 D 55,5 H 86,5 cm
SH 48,5 cm



Model 4072
Office Armchair
W 72 D 70 H 81,5-91,5 cm
SH 44,5-54,5 cm

Shell:
10 standard colours

Base:
Black, Polished aluminium.

Armrests:
Black

Upholstery:
Leather or fabric

Shell:
10 standard colours

Base:
Black, Polished aluminium.

Armrests:
Black

Upholstery:
Leather or fabric

PRODUCT SHEET DOWNLOAD
FREDERICIA.COM

Pato Executive

Pato Executive
Upholstery: Leather Primo 75 Cognac
Base: Black

Mesa Table
Table Top: Black linoleum
Base: Black





Pato Executive. Upholstery: Leather Max 98 Black. Base: Polished aluminium.
6286 Table. Wood: Smoked oak.
Soborg Chair. Upholstery: Leather Primo 88 Black. Base: Black.



Pato Executive. Upholstery: Leather Max 98 Black. Base: Polished aluminium.

Distinctive & durable

The silky surface, bevelled edge and linear legs are subtle signature details of a sleek chair that's loaded with advantages. The Pato Sledge. Every detail has a purpose in this light, versatile, stackable chair, where every part is 100% recyclable. A distinctive design that's durable and easy to imagine in conference halls, meeting rooms and countless public sectors.

Pato's shell has been developed with a surface finish that's unprecedented for a chair of this kind, setting a new standard for polypropylene. Smooth to the touch, the shape is engineered for hours of comfortable seating. With a faceted edge to ensure that the chair conforms optimally to the body. The upholstered version adds endless options for colours and textures that can complement any interior imaginable.



Welling/Ludvik, 2013

Chair, Sledge base
Model 4100
Without upholstery
Model 4101
Seat upholstered
Model 4102
Fully upholstered
W 54,5 D 51 H 79 cm
SH 46,5 cm

Armchair, Sledge base
Model 4110
Without upholstery
Model 4111
Seat upholstered
Model 4112
Fully upholstered
W 55,5 D 51,5 H 79 cm
SH 46,5 cm

Stool, Sledge base
Model 4310
Without upholstery
Model 4311
Seat upholstered
Model 4312
Fully upholstered
W 49,5 D 46,5 H 83-93 cm
SH 67-77 cm

Barstool, Sledge base
Model 4300
Without upholstery
Model 4301
Seat upholstered
Model 4302
Fully upholstered
W 47 D 50 H 97-109 cm
SH 67-77 cm

Shell:
10 standard colours

Base:
Black, Chrome.

Upholstery:
Leather or fabric

Shell:
10 standard colours

Base:
Black, Chrome.

Armrests:
Black aluminium
Upholstery:
Leather or fabric

Shell:
10 standard colours

Base:
Black, Chrome.

Upholstery:
Leather or fabric

Shell:
10 standard colours

Base:
Black, Chrome.

Upholstery:
Leather or fabric

PRODUCT SHEET DOWNLOAD
FREDERICIA.COM

Measurements are based on models without upholstery. Measurements may vary between 0,5-1,5 cm when upholstered

Pato Sledge

Pato Sledge Chair
Shell: Storm
Base: Chrome







Lounge Chairs

While our associations with lounging haven't changed, the locations for lounging has. Lounge chairs have moved from an open and inviting place to relax at home to corporate settings. In wireless offices, where work can take place anywhere, lounge seating is a key element for any meeting of the minds. In hotels, retail spaces and public venues, a lounge chair functions much like a pause button. Allowing you to sit back, relax and enjoy the moment.

The Spanish Chair	144
The Hunting Chair	150
2207 Chair, 2204 Wing Chair & 2202 Ottoman	152
Mogensen 2334 Lounge Chair	156
The Canvas Chair	158
Wegner Ox Chair	164
Wegner Queen Chair	170
Wegner J16 Rocking Chair & Stool	172
Wegner 1788 Easy Chair	176
Swoon Lounge & Swoon Ottoman	178
Swoon Lounge Petit	186
Spine Lounge Chair	190
Ditzel Lounge Chair	194
Corona Chair & Corona Ottoman	198
The A-Chair	204
Savannah Chair	208
Savannah Chair Petit	212
Pato Lounge	214
Eyes Lounge	218
Calmo Chair & Calmo Ottoman	222
Mono Pouf	224

One of Mogensen's masterpieces

Andalucia was the backdrop of inspiration for one of Borge Mogensen's many masterpieces – The Spanish Chair. While travelling through Spain, he observed an ornate chair with wide armrests, a traditional style involving Spain's medieval form of furniture construction.

The chair was launched in 1958 as part of an innovative living space exhibition at the Copenhagen Cabinetmaker's Guild, where all tables were removed from the floor to create an open living area.

The wide armrests serve as a practical place for a glass, allowing the user to dispense with occasional tables or other furniture. In doing so, he achieved a more open and informal space for relaxing and conversing.

The Spanish Chair has quite a strong presence, with its solid oak construction and sturdy, high quality leather. Over time, as the leather expands, the adjustable straps can be tightened. Allowing you to sit securely and comfortably from day one – and for the rest of your life. One of Mogensen's most celebrated designs, it reflects his unique angle on modernity.

A classic found in corporate settings, hotels, galleries and private residences around the globe.



Model 3237
Chair
Page 68



Model 2226
Lounge Chair
W 82,5 D 60 H 67 cm
SH 33 cm

Borge Mogensen, 1958

Wood:
Oak soap, Oak oil, Oak light oil, Oak black lacquered, Smoked Oak oil, Walnut.

Saddle leather:
Natural or Cognac with brass buckles, Black with chrome buckles.

PRODUCT SHEET DOWNLOAD
FREDERICIA.COM

The Spanish Chair

The Spanish Chair
Leather: Black saddle leather
Wood: Walnut

Pal Table
Table top: Walnut oil
Base: Brushed stainless steel





The Spanish Chair. Leather: Cognac saddle leather. Wood: Smoked oak oil.
Calmo Sofa. Upholstery: Clay 12. Base: Black metal.
Pal Table. Table top: Walnut oil. Base: Brushed stainless steel.
Pilot Stone Coffee Table. Table top: Grey Pietra Marble. Legs: Black metal.
Hydro Vase
Lotus Bowl





The Spanish Chair. Leather: Natural saddle leather. Wood: Oak soap.

The Spanish Chair. Leather: Saddle leather. Wood: Oak soap.
Pal Table. Table top: Oak light oil. Base: Brushed stainless steel.
Sequoia Pouf. Upholstery: Bouclé
Fellow Lamp



Understated & authentic

The annual exhibition by the Copenhagen Cabinetmakers' Guild was an important platform of local and international exposure for Danish talent. Established in 1927, it provided the opportunity to showcase work produced by the designers, architects and cabinetmakers behind the initiative.

In 1950, Børge Mogensen rose to the occasion with his presentation of the Hunting Chair, his earliest example of designing furniture with a solid wood framework. Combined with saddle leather, given its sturdy, resilient qualities, which he used to form the seat and back.

The Hunting Chair is one of Mogensen's most eye-catching designs. Seen from the side, what's most notable about the chair is the sharp diagonal slope from the edge of the front seat measuring only 30 cm above the floor.

The Hunting Chair was also the first time Mogensen used an adjustable buckle closure to secure the leather behind the seat and back, which all slot into the wooden frame. A decision that not only allowed for easy construction, it also resulted in quite a comfortable chair that automatically adjusts to your body weight.

The overall look and logical construction were inspired by Spain's medieval Andalusian furniture, something that Mogensen would return to time and time again, as seen in his subsequent development of The Spanish Chair.



Borge Mogensen, 1950

Model 2229
Lounge Chair
W 70,5 D 87 H 67 cm
SH 28 cm

Wood:
Oak soap, Oak oil, Oak light oil, Oak
black lacquered, Smoked oak oil.

Saddle leather:
Natural or Cognac with brass buckles,
Black with chrome buckles.

PRODUCT SHEET DOWNLOAD
FREDERICIA.COM

The Hunting Chair

The Hunting Chair
Leather: Saddle
Wood: Oak soap



A comfort zone

Borge Mogensen was a firm believer that furniture should give people the leading role, instead of forcing people to adapt to furniture. Such is the case with the 2207 Chair.

The graceful slope of the armrests and slight inclination of the back contribute to the chair's ability to comfortably accommodate the body. Mogensen's Wing Chair features a sharply-defined silhouette with a soft, encompassing interior. Boasting a high, cushioned back and neck rest, the curved armrests provide a natural feeling of comfort, enhanced by the ample seat cushion.

The result is an enclosed feeling from a chair that invites you to relax. The Ottoman makes for an ideal companion to either the Wing Chair or the 2207 Chair. Capturing Mogensen's perfect sense of proportions, the base and cushion correspond to the chairs. As a footrest, the Ottoman adds an extra dimension of comfort, allowing you to stretch out and relax even more.



Borge Mogensen, 1963

Model 2207
Lounge Chair
W 69 D 84 H 84 cm
SH 43 cm

Model 2204
Lounge Chair
W 69 D 88 H 106 cm
SH 43 cm

Model 2202
Ottoman
W 58 D 58 H 43 cm

Wood:
Oak soap, Oak oil, Oak light oil,
Oak black lacquered, Walnut oil.

Upholstery:
Limited selection of leathers
and fabrics

Wood:
Oak soap, Oak oil, Oak light oil,
Oak black lacquered, Walnut oil.

Upholstery:
Limited selection of leathers
and fabrics

Wood:
Oak soap, Oak oil, Oak light oil,
Oak black lacquered, Walnut oil.

Upholstery:
Limited selection of leathers
and fabrics

PRODUCT SHEET DOWNLOAD
FREDERICIA.COM

2207 Chair, 2204 Wing Chair & 2202 Ottoman

Mogensen Wing Chair
Upholstery: Leather Vegeta 90 Natural
Legs: Oak soap







Mogensen 2207 Club Chair. Upholstery: Leather Max 98 Black. Legs: Oak black lacquered.

Spanish Dining Chair. Upholstery: Natural saddle leather. Wood: Oak soap.
Library Table. Wood: Oak oil.
Mogensen 2207 Club Chair. Upholstery: Leather Trace 8146 Olive. Legs: Oak oil.
Fellow Lamp

An easy chair

An easy chair designed by Børge Mogensen's son, architect Peter Mogensen, as the completion of his father's last furniture series, initiated in 1971.



Børge Mogensen, 1996

Model 2334
Lounge Chair
W 85 D 78 H 78 cm
SH 43 cm

Wood:
Oak light oil, Oak black lacquered.

Upholstery:
Limited selection of leathers
and fabrics

PRODUCT SHEET DOWNLOAD
[FREDERICIA.COM](https://www.fredericia.com)

Mogensen 2334 Lounge Chair



Earthy informality

Canvas teamed with wood define a more casual, down-to earth lifestyle in this structural chair with a strong presence by Børge Mogensen.

Reflecting values all the more relevant today, given its broad width that allows people to merge work and play in comfort. The Canvas Chair exemplifies Børge Mogensen's talent for functionally-driven designs with a focus on simple forms that capture the essence of an idea. With nothing to add or subtract. Drawing on his preference for natural materials, Mogensen used flat canvas as the seat and back suspended between round pieces of wood, together with his trademark use of horizontal and vertical lines for the frame.

The result is contrast and a remarkable sense of balance. Although it was designed in 1970 as a reaction to flashy furniture from the 1960s, The Canvas Chair takes on even more relevance today, given its earthy informality and honest materials. Boasting an unadorned authenticity which modern audiences find especially appealing. Prime European oak and linen canvas are both available in black or natural coloured versions, with an optional loose seating cushion in canvas or leather.

One of the last pieces Mogensen designed before his untimely death in 1972, The Canvas Chair has remained in our archives ever since – until now.



Børge Mogensen, 1970

Model 2031
Lounge Chair
W 74 D 65,5 H 76 cm
SH 41,5 cm

Wood:
Oak soap, Oak light oil, Oak black
lacquered

Canvas:
Natural canvas
Black chair available with black canvas

PRODUCT SHEET DOWNLOAD
FREDERICIA.COM

The Canvas Chair

Canvas Chair
Canvas: Natural
Wood: Oak soap





Canvas Chair. Canvas: Black. Base: Oak black lacquered.

Canvas Chair. Canvas: Black. Base: Oak black lacquered.
Calmo Sofa. Upholstery: Clay 12. Base: Black.
Tableau Coffee Table.







Canvas Chair. Canvas: Natural. Base: Oak soap.

Canvas Chair. Canvas: Natural. Wood: Oak light oil.
Pal Table. Table top: Walnut oiled. Base: Brushed stainless steel.
Calmo Sofa. Upholstery: Clay 12. Base: Black.

An iconic statement piece

The Ox Chair by Hans J. Wegner is an iconic statement piece with an irrefutable presence. A bold, sculptural chair that challenged the understated aesthetics of Danish design at the time, with its distinctive headrest referencing ox horns and its voluminous body. It demonstrates his organic, artistic approach to furniture and desire to redefine traditional seating.

The Ox Chair is arguably his most striking design, purportedly inspired by his fascination with Picasso's abstract paintings, claiming that design doesn't always have to be so "dreadfully serious." Wegner chose to furnish his own home with the Ox Chair, as it was one of his personal favourites.



Hans J. Wegner, 1960

Model 1000
Lounge Chair
W 99 D 99 H 92 cm
SH 36 cm

Model 1002
Ottoman
W 75 D 55 H 36 cm

Base:
Brushed stainless steel, Black.

Upholstery:
Leather or fabric

Base:
Brushed stainless steel, Black.

Upholstery:
Leather or fabric

PRODUCT SHEET DOWNLOAD
FREDERICIA.COM

Wegner Ox Chair

Ox Chair and Ottoman
Upholstery: Leather Primo 88 Black
Base: Brushed chrome

Pai Table
Table top: Walnut oil
Base: Brushed stainless steel

Meadow Lamp







Ox Chair. Upholstery: Leather Omni 307 Cognac. Base: Brushed chrome.

Ox Chair. Upholstery: Leather Omni 307 Cognac. Base: Brushed chrome.
Calmo Sofa. Upholstery: Clay 12. Base: Black metal.
Piloti Stone Coffee Table. Table top: Grey Pietra Marble. Legs: Black metal.
Pai Table. Table top: Oak light oil. Base: Brushed stainless steel.
Mono Pouf. Upholstery: Grand Linen Natural.
Locus Bowl



Ox Chair. Upholstery: Leather Max 96 Brown. Base: Brushed chrome.
Calmo Sofa. Upholstery: Clay 12. Base: Black metal.
Islet Coffee Table. Wood: Oak light oil.
Pal Table. Table top: Walnut oil. Base: Stainless steel, brushed
Post Chair. Upholstery: Leather Omni 377 Dark Brown. Wood: Oak light oil.
Post Table. Wood: Oak light oil.
Sequoia Pouf. Upholstery: Wool.



Regal yet relaxed

The feminine counterpart to the Ox Chair is Hans J. Wegner's Queen Chair, which shares many of the same features. With its ample, almost cylindrical armrests and high, majestic back that extends up to support the neck, the Queen Chair is an equal match for the Ox Chair's masculine presence. Regal yet relaxed, the Queen Chair embodies Wegner's belief that for a design to be striking it must be based on practicality.

In 1960, the Ox Chair and the Queen Chair were presented together at the Dansk K best evne exhibition, an annual showcase for Danish industry and crafts, which included an exhibition of furniture. It was a forerunner to trade fairs as a meeting place for craftsmen, industrialists and merchants to purchase and promote Danish crafts.

The Queen Chair is one of Wegner's most elegant lounge chairs. It's a true icon in its own right, admired for its sophisticated construction and sculptural aesthetic. It captures the essence of Wegner's innovative approach to design, which is at once organic and artistic. While at the same time, firmly based on functionalism.



Hans J. Wegner, 1960

Model 1010
Lounge Chair
W 92 D 99 H 90 cm
SH 36 cm

Model 1002
Ottoman
W 75 D 55 H 36 cm

Base:
Brushed stainless steel, Black.

Upholstery:
Leather or fabric

Base:
Brushed stainless steel, Black.

Upholstery:
Leather or fabric

PRODUCT SHEET DOWNLOAD
FREDERICIA.COM

Wegner Queen Chair

Queen Chair and Ottoman
Upholstery: Divina Melange 220
Base: Brushed chrome
Hydro Vase



The quintessential Danish rocking chair

Hans J. Wegner showed an early interest in the rocking chair as a design object and J16 was one of his first chairs ever put into production. The very first version was designed in 1944. After a process to make the chair easier to produce the production could start. Wegner's J16 has proved so viable that it has been in demand ever since it first came on the market.

For Wegner, a chair was a work of art conceived to support the human body. In all his designs, it's easy to recognise his fondness for form and function, where ergonomics play a primary role. Freedom of movement was also key for Wegner, who made every effort to ensure comfort, achieved by his precise engineering of the elements that contribute to the graceful rocking movement.

The natural paper cord forming the seat adds support while creating a subtle contrast in texture to the smooth wooden structure.

The J16 Stool is the rocking chair's faithful companion. Featuring the same cord and visual lingo, its sturdy structure of solid wood enables it to double as a small stool. One of Wegner's most widely recognised pieces, the J16 is part of our proud heritage. It is cherished around the world as the quintessential Danish modern rocking chair.



Hans J. Wegner, 1944/50

Model 16000
Rocking Chair
W 62 D 85 H 107 cm
SH 42 cm

Model 16002
Stool
W 52 D 38 H 42,5 cm

Wood:
Oak soap, Oak black lacquered, Oak light oil, Walnut oil.

Seat:
Natural paper cord
Black chair available with black paper cord

PRODUCT SHEET DOWNLOAD
FREDERICIA.COM

Wegner J16 Rocking Chair & Stool

J16 Rocking Chair & Stool
Paper cord: Natural
Wood: Oak light oil
Cushion: Leather Max 96 Dark Brown







J16 Rocking Chair. Paper Cord: Natural. Wood: Walnut oil.

J16 Rocking Chair. Paper Cord: Natural. Wood: Black lacquered oak.

Sculptured spoke-back

The origins of this chair began back in 1945, when Hans J. Wegner and his colleague and friend Børge Mogensen designed a presentation for the annual exhibition of the Copenhagen Cabinetmaker's Guild called "A Home for the Future". The focal point of their stand was a living room, where they presented a fresh vision for functional furniture.

The outcome for Wegner was his lightweight wooden design with interchangeable cushions. Wegner's 1788 Chair was finessed years later in 1974 to arrive at the current design.

True to its original concept, the spoke-back chair features a stunning profile in the sloping armrests, reflecting his signature sculptural details and talent for working with wood.

As part of the Spoke-Back Collection, the 1788 Chair has an exposed wooden construction that's an intrinsic part of the design, as well as cushions attached with visible straps. The Spoke-Back Collection reflects Wegner's work with Windsor chair methodology.



Hans J. Wegner, 1974

Model 1788
Lounge Chair
W 65,5 D 70 H 88 cm
SH 43,5 cm

Wood:
Oak soap, Oak black lacquered.

Upholestry:
Leather or fabric

PRODUCT SHEET DOWNLOAD
[FREDERICIA.COM](https://www.fredericia.com)

Wegner 1788 Easy Chair

1788 Chair
Upholstery: Leather Omni 301 Black
Wood: Oak black lacquered

Mono Pouf
Upholstery: Grand linen natural

Hydro Vase



An open invitation to relax

With its continuous curves, lush look and sculptured shape, Swoon echoes Space Copenhagen's desire for you to enjoy life at a slow pace. Originally launched for the 11 Howard Hotel in New York, the Swoon Lounge is an open invitation to luxuriate in comfort. Based on their extensive experience designing high-end hotel interiors and Michelin-star restaurants, Space Copenhagen created Swoon to fill a gap missing in the market – a hybrid of a lounge chair and an armchair with the benefits of both.

The singular shell merges the back, seat and armrests into one entity, allowing for exceptional support and a fit that feels natural. The seat and back cushions are also attached as one piece for endless hours of comfort.

Swoon is suitable for hotel lobbies, VIP suites, restaurant reception areas, upscale bars, lounges and private residences. Of course, the perfect companion to any lounge chair is an ottoman. The Swoon Ottoman not only adds to your ability to stretch out and relax even more, it's a decorative element in its own right. Ideal as a pouf for punctuating any space with style.



Model 1777
Armchair, Wood base
Page 96



Model 1770
Lounge Chair
W 90 D 88,5 H 83,5 cm
SH 36 cm



Model 1771
Ottoman
W 63 D 52,5 H 40,5 cm

Space Copenhagen, 2016/18

Wood:
Oak lacquered, Smoked oak stained,
Walnut lacquered, Oak black lacquered.

Upholstery:
Leather or fabric

Wood:
Oak lacquered, Smoked oak stained,
Walnut lacquered, Oak black lacquered.

Upholstery:
Leather or fabric

PRODUCT SHEET DOWNLOAD
FREDERICIA.COM

Swoon Lounge & Ottoman

Swoon Lounge Chair
Upholstery: Byram 161
Legs: Walnut lacquered

Pai Table
Table top: Walnut oil
Base: Brushed stainless steel

Fellow Lamp



Swoon Lounge Chair. Upholstery: Byram 361. Legs: Walnut lacquered.
Pal Table. Table top: Oak oil. Base: Brushed stainless steel.
Sequoia Pouf. Upholstery: Bouclé.







Swoon Lounge Chair. Upholstery: Capture 4601.

Swoon Lounge Chair. Upholstery: Ruskin 10. Legs: Walnut lacquered.
Tableau Coffe Table





Location: Park House,
London



Compact & curvaceous

With its continuous curves and lush look, The Swoon Lounge Petit has a luxurious look, with a sculptured silhouette that appears elegant and relaxed. The same feeling is achieved once you sit down, supported by a singular shell that curves to form the seat, arms and back in one piece. The soft, contoured cushions add an extra element of comfort and dimension.

A line extension from the Swoon Lounge, the Swoon Lounge Petit has a similar shape but it's somewhat smaller and more upright. Available in a variety of alluring fabrics and different bases, it's a comfy, well-crafted, curvaceous design, ideal for hotel lobbies and suites, corporate lounge areas, upscale bars and homes.



Model 1777
Armchair, Wood base
Page 96



Model 1774
Lounge Chair, Wood base
W 74 D 76 H 85 cm
SH 40 cm



Model 1776
Swivel Lounge Chair, X-base
W 74 D 76 H 85 cm
SH 40 cm

Space Copenhagen, 2019

Wood:
Oak lacquered, Smoked oak stained,
Walnut lacquered, Oak black lacquered.

Upholstery:
Leather or fabric

Base:
Black, Polished aluminium.

Upholstery:
Leather or fabric

PRODUCT SHEET DOWNLOAD
FREDERICIA.COM

Swoon Lounge Petit

Swoon Pett Swivel Chair
Upholstery: Carlotto 900
Base: Black





Swoon Chair. Upholstery: Carlotta 200.

Swoon Lounge Petit. Upholstery: Sinequanon 001. Legs: Oak black lacquered.
Silhouette Mirror. Wood: Walnut oil.
Fellow Lamp



Fluid lines in a solid design

The Spine Lounge Suite is a striking example of fluid lines in a solid, concise design that exudes luxury from every angle. Seat and back cushions are supported by a singular structure in solid wood. The detailing on the wooden back makes the chair as attractive when placed in the middle of a space as it is against a wall.

Its smaller sibling is the Spine Lounge Petit. Both chairs are angled a bit back for hours of lounging in comfort. With hand-sewn cushions and piping as a discrete detail. While both chairs lend themselves to hotel lobbies, lounges and upscale bars, the smaller Spine Lounge Petit can easily work in a private living room paired together or as a stand-alone.



Space Copenhagen, 2016/19

Model 1714
Lounge Wood Chair,
front upholstered
W 65 D 70 H 75 cm
SH 40 cm

Model 1710
Lounge Suite Chair
W 80 D 81 H 71 cm
SH 41 cm

Model 1711
Lounge Suite Chair Petit
W 65 D 70 H 69 cm
SH 41 cm

Wood:
Oak lacquered, Black lacquered.

Upholstery:
Leather or fabric

Wood:
Oak lacquered, Oak black lacquered.

Upholstery:
Leather or fabric

Wood:
Oak lacquered, Oak black lacquered.

Upholstery:
Leather or fabric

PRODUCT SHEET DOWNLOAD
FREDERICIA.COM

Spine Lounge Chair

Spine Lounge Suite Petit
Upholstery: Leather Omni 301 Black
Base: Oak black lacquered





Spine Lounge Suite. Upholstery: Leather Omni 301 Black. Base: Oak black lacquered.
Pal Table. Table top: Walnut oil. Base: Brushed stainless steel.



An escape into spaciousness

Designed by Nanna Ditzel and Jørgen Ditzel in 1953, the Ditzel Lounge Chair is a welcome escape into spaciousness. A modern take on the traditional easy chair, offering a stylish seating solution for settings in search of intimacy.

Adding extra comfort is the ample width, along with the slightly curved back and armrests as a single entity.

The high-pressured PUR foam shell is enforced with a steel frame and upholstered in a variety of our exclusive fabrics, including bouclé. It's your invitation to escape into a cosy yet spacious comfort zone, which makes the Ditzel Lounge Chair especially attractive in contexts that encourage connectivity.



Nanna Ditzel & Jørgen Ditzel, 1953

Model 2632
Ditzel Lounge Chair
W 81 D 73 H 72 cm
SH 37 cm

Model 2631
Ditzel Lounge Sheepskin Chair
W 81 D 73 H 72 cm
SH 37 cm

Wood:
Oak Lacquered, Smoked oak stained,
Oak black lacquered, Walnut lacquered.

Wood:
Oak Lacquered, Smoked oak stained,
Oak black lacquered, Walnut lacquered.

Upholstery:
Leather or fabric.

Upholstery:
Sheepskin.

PRODUCT SHEET DOWNLOAD
FREDERICIA.COM

Ditzel Lounge Chair

Ditzel Lounge Chair
Upholstery: Sheepskin
Legs: Walnut lacquered

Silhouette Mirror
Wood: Walnut oil

Pen Table
Wood: Smoked oak oil

Mono Pouf
Upholstery: Leather Omni 307 Cognac

Meadow Lamp



Ditzel Lounge Chair.
Upholstery: Sisu 105
Legs: Oak oil





Challenging conventional seating

The Corona Chair by Poul M. Volther is an experimental take on Danish design. Sculptural, eye-catching and original, the Corona is a lesson in geometry. A consequent design with elliptical-shaped, upholstered seat pads descending in size. It's an intriguing approach that challenges conventional seating, resulting in Corona's image as a design icon coveted the world over.

Volther was a firm believer in functionalism. An architect and designer who trained as a cabinetmaker, he was encouraged by his colleague Hans J. Wegner to work at the design studio of the Danish Wholesale Cooperative under the leadership of Borge Mogensen, who stayed until 1950, leaving Volther in charge. There Volther experimented with designs that could minimise the use of fabric, in short supply at the time.

Truly Volther's masterpiece, Corona has starred in numerous movies and music videos and continues its stage career to this day. Given Corona's rare combination of organic shapes and streamlined graphics, the chair is a favourite in business environments, such as executive offices and reception areas, as well as private homes.



Poul M. Volther, 1964

Model 5000
Lounge Chair
W 88 D 82 H 97 cm
SH 42 cm

Model 5002
Ottoman
W 75 D 49 H 47 cm

Base:
Brushed chrome, Black.

Upholstery:
Leather or fabric

Base:
Brushed chrome, Black.

Upholstery:
Leather or fabric

PRODUCT SHEET DOWNLOAD
FREDERICIA.COM

Corona Chair & Ottoman

Corona Chair
Upholstery: Fiord 961
Base: Brushed chrome





Corona Chair. Upholstery: Fiord 961. Base: Brushed chrome

Corona Chair. Upholstery: Leather Primo 88 Black. Base: Brushed chrome.
EJ66 Table. Table top: White Carrara. Base: Stainless steel.





Corona Chair. Upholstery: Fiord 961. Base: Brushed chrome
Corona Table. Table top: Glass plate. Base: Brushed chrome



Modern in any milieu

Jens Risom is known for introducing a Scandinavian design sensibility to the American market. There he pursued a successful career designing an array of pieces which stemmed from functionality, imbued with a New York sense of style and savoir-faire. Risom went on to leave a legacy of stunning, streamlined designs. Echoing his sentiment that "when sizing up a chair, do it sitting down", Risom's design of the A-Chair fuses comfort with a well-tailored sense of class.

With the A-frame in the back that cradles the chair, it began as a functional detail and became the signature trait. The slight angle of the back is mirrored in the angles of the arms, adding a sense of equilibrium to the leaned back look. The two-piece back and seat cushion add comfort and are discretely incorporated into the design as graphic elements.

It's a graceful, comfort-conscious chair driven by a purpose. Originally conceived in 1961, the A-Chair will always look modern in any milieu, exquisitely executed so lounging feel likes a luxury.



Jens Risom, 1961

Model 6540
Lounge Chair, Wood base
W 78 D 87 H 87 cm
SH 42 cm

Model 6542
Lounge Chair, Metal base
W 78 D 87 H 87 cm
SH 42 cm

Wood:
Oak lacquered, Black lacquered,
Walnut lacquered.

Upholstery:
Leather or fabric

Metal base:
Black, Matt chrome.

Upholstery:
Leather or fabric

PRODUCT SHEET DOWNLOAD
FREDERICIA.COM

The A-Chair

A-Chair Metal Base
Upholstery: Steelcut Trio 124
Base: Matt chrome
Meadow Lamp





A-Chair. Upholstery: Tonus 135. Base: Black lacquered.
Magazine Table
Tableau Coffee Table



A-Chair. Upholstery: Sunniva 717. Base: Walnut lacquered.

Leather forms the framework

The Savannah Chair is a masterful merging of structure, softness and materiality. Saddle leather forms a framework that wraps around the soft seat and back cushions supported by a solid wooden core. The two smaller inner cushions for the armrests enhance the comfort with almost a cocooning feeling.

The chair showcases our heritage of craftsmanship and love of natural materials, seen in the use of leather and fine woodworking. A variety of leather, wood finishes and fabrics gives you the freedom to create a matching, monotone colour scheme. Or create contrast with a mix of tones.



Model 8805
Lounge Chair
Page 212



Model 8801
Lounge Chair
W 89 D 84 H 80 cm
SH 42 cm

Monica Förster, 2015

Wood:
Oak light oil, Black lacquered.

Saddle leather on frame:
Black or Cognac

Upholstery (cushions):
Fabric

PRODUCT SHEET DOWNLOAD
FREDERICIA.COM

Savannah Chair







Savannah Chair. Upholstery: Leather 814 Trace / Zero 0002. Wood: Oak light oil.

Structure, softness and materiality

The Savannah series represents a merging of structure, softness and materiality. The outer frame in solid wood is wrapped in leather or canvas while the inside is upholstered with plush comfort.

The Savannah series was designed by the acclaimed Swedish designer Monica Förster as a modern interpretation of Scandinavian design principles. Savannah is perfect for corporate break-out areas, hospitality lounges or private homes.



Monica Förster, 2022

Model 8801
Lounge Chair
Page 208

Model 8805
Lounge Chair
W 82,5 D 60 H 67 cm

Wood:
Oak light oil, Black lacquered.

Saddle leather on frame:
Black or Cognac

Upholstery (cushions):
Fabric

PRODUCT SHEET DOWNLOAD
FREDERICIA.COM

Savannah Chair Petit



Calibrated for comfort

One look at Pato Lounge and don't be surprised if you find yourself inclined to relax just at the sight of it. The curve of the seat mirrored in the back are united in one supportive shell finessed for comfort. The broad width allows you to nestle in while in a hotel lobby, waiting room or private living room. To relax while at work or after work in a bar.

Given its minimalistic aesthetic, the Pato Lounge leaves room for endless opportunities to customise. The wooden base exudes a touch of warmth while the swivel base allows for freedom of movement. Choose from our curated selection of fabrics to fine-tune the visual impression from subtle to striking.



Model 4372
Lounge Chair, Sledge base
W 63 D 69 H 72 cm
SH 40 cm



Model 4392
Lounge Chair, Wood base
W 63 D 69 H 72 cm
SH 40 cm



Model 4362
Lounge Chair, 4 Leg
W 63 D 69 H 72 cm
SH 40 cm

Welling/Ludvik, 2016/17/18

Metal base:
Black, Chrome.

Upholstery:
Leather or fabric

Wood:
Oak lacquered, Oak black lacquered,
Smoked oak stained.

Upholstery:
Leather or fabric

Metal base:
Black, Chrome.

Upholstery:
Leather or fabric

Pato Lounge

Pato Lounge
Upholstery: Leather Max 96 Dark Brown
Wood: Smoked oak stained

Pai Table
Table top: Walnut oil
Base: Black

Meadow Lamp



Pato Swivel Lounge Chair. Upholstery: Leather Max 96 Dark Brown.
Base: Polished aluminium.





Stay a while

With its gentle curves and slight angle back, the Eyes Lounge is a visual cue to sit back and stay a while. To relax in a hotel lobby, hold an informal meeting or work on your laptop in your living room.

The simple shape lends itself to the opportunity to customise. Including variants with wooden legs, a swivel base or a 4-leg tube.

Designers Foersom & Hiort-Lorenzen see quality and comfort are inseparable. It wouldn't be a long-lasting design to have one without the other.

With the Eyes Lounge Chair, you have all that in a stylish expression suitable for any occasion and any sector, whether corporate, commercial, hospitality or private.



Johannes Foersom &
Peter Hiort-Lorenzen, 2007

Model 4850
Lounge Chair, 4 Leg
W 65 D 71 H 72 cm
SH 38 cm

Model 4854
Lounge Chair, Wood base
W 65 D 71 H 72 cm
SH 39 cm

Model 4856
Lounge Armchair, Wood base
W 65 D 71 H 72 cm
SH 39 cm

Model 4858
Swivel Lounge Chair, X-base
W 65 D 71 H 72 cm
SH 39 cm

Base:
Black, Brushed chrome.
Upholstery:
Leather or fabric

Wood:
Oak lacquered, Black lacquered,
Smoked oak stained.
Upholstery:
Leather or fabric

Wood:
Oak lacquered, Black lacquered,
Smoked oak stained.
Upholstery:
Leather or fabric

Base:
Black, Polished aluminium.
Upholstery:
Leather or fabric

PRODUCT SHEET DOWNLOAD
FREDERICIA.COM

Eyes Lounge

Eyes Lounge Wood Base
Upholstery: Carlotto 900
Base: Black lacquered

Pal Table
Table top: Oak oil
Base: Black





Eyes Lounge Wood Base. Upholstery: Carlotto 900. Base: Brushed chrome.

Eyes 4 Leg Barstool. Upholstery: Gentle 183. Base: Black.
Eyes Lounge 4 Leg. Upholstery: Carlotto 900. Base: Black.
Meadow lamp



Clean, uncluttered lines

With the Calmo Chair, straight lines and discrete curves converge in a singular aesthetic that signals serenity. The look is linear and expansive in the structured exterior, softened by a graceful curve on the inside of the armrests, accompanied by soft tailored and back cushions.

Echoing the same clean design lingo is the Calmo Ottoman. Perfectly proportioned to partner with the Calmo Chair or Sofa, add it as an extra element of comfort for stretching, relaxing and lounging. Or for placing books or blankets. The depth of the seat and roomy width make the pair a cosy option for working at home or adding a touch of home to work.



Hugo Passos, 2019

Model 5621
Lounge Chair 80
W 90 D 90 H 75,5 cm
SH 41 cm

Model 5620
Ottoman 80
W 80 D 95 H 41 cm

Wood base:
Oak lacquered, Smoked oak stained.

Wood base:
Oak lacquered, Smoked oak stained.

Metal base:
Black, Matt chrome.

Metal base:
Black, Matt chrome

Upholstery:
Leather or fabric

Upholstery:
Leather or fabric

PRODUCT SHEET DOWNLOAD
FREDERICIA.COM

Calmo Chair & Ottoman

Calmo Lounge Chair. Upholstery: Fiord 271. Base: Smoked oak stained.
Pilot Stone Coffee Table. Table top: Grey Pietra marble.
Fellow Lamp



The essence of versatility

The Mono Pouf is a singular concept with a multitude of possibilities. Either as an appealing seating option, side table, footrest or decorative item, the cylindrical shape in different circumferences and heights makes Mono a welcome addition to any space. From retail and commercial venues to the hospitality and private sectors.



Model 7421
Pouf
D 39 H 43 cm



Model 7423
Pouf
D 55 H 38 cm



Model 7425
Pouf
D 90 H 38 cm

Birgitte Due Madsen & Jonas Trampedach,
2020

Upholstery:
Leather or fabric

Upholstery:
Leather or fabric

Upholstery:
Leather or fabric

PRODUCT SHEET DOWNLOAD
[FREDERICIA.COM](https://www.fredericia.com)

Mono Pouf

Mono Pouf

Upholstery:
Grand linen natural
Leather Omni 301 Black
Leather Omni 307 Cognac
Leather Vegeta, 90 Natural



Sofas

Armed with over 100 years of sofa experience, our sofa competence is extensive. Our expertise extends from designing sofas to addressing the changing role of sofas in the landscape of our lives. Today, sofas have moved from the epicentre of private living rooms to flexible workspaces. As a place to luxuriate in a hotel suite, able to make a public space feel more private and a reception area more inviting. Add a sofa to a formal setting and people tend to relax. Or transform a cold interior into a warm atmosphere.

Mogensen 2212 & 2213 Sofa	230
Mogensen 2208 & 2209 Sofa	234
Mogensen Coupé Sofa	236
Mogensen 2335 & 2333 Sofa	238
Delphi Sofa	240
Delphi Elements	242
Spine Lounge Sofa & Daybed	248
EJ315 Sofa	252
The Spoke-Back Sofa	258
No.1 Sofa	262
JG Sofa	264
Savannah Sofa	268
Calmo Sofa	270
Konami Sofa	276
Haiku Sofa	280
EJ280 Sofa	284
EJ280 Elements	290
EJ288 Sofa	292
EJ295 Chaise Sofa	296
EJ220 Sofa	298
EJ220 Elements	300

Designed for Mogensen's own home

Borge Mogensen advocated the idea that furniture should create a sense of tranquility, with a modest appearance that encourages people to live their lives unpretentiously.

The 2213 Sofa embodies all of that and more. The armrests feature a curve upwards towards the back, as a subtle, signature detail in a truly comfortable 3-seat sofa that Mogensen designed for his own home in 1962. With generous proportions and leather craftsmanship that fulfil another ambition of Mogensen – to create the ultimate sofa.

The 2212 Sofa is a 2-seater version with all the same attributes and appeal. Both are classics found in executive offices, embassies, government buildings and private homes the world over.

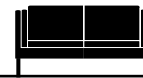

Borge Mogensen, 1962

Model 2212
Sofa, 2 seater
L 158 cm D 81 H 80
SH 43 cm

Model 2213
Sofa, 3 seater
L 221 cm D 81 H 80
SH 43 cm

Wood:
Oak soap, Oak oil, Oak light oil,
Oak black lacquered, Walnut oil.

Upholstery:
Limited selection of leathers and fabrics

Wood:
Oak soap, Oak oil, Oak light oil,
Oak black lacquered.

Upholstery:
Limited selection of leathers and fabrics

PRODUCT SHEET DOWNLOAD
FREDERICIA.COM

Mogensen 2212 & 2213 Sofa

2213 Sofa
Upholstery: Leather Vegeta, 90 Natural
Legs: Oak soap

The Spanish Chair
Leather: Natural saddle leather
Wood: Oak soap





2213. Upholstery: Leather Max 96 dark brown. Legs: Walnut.
2204. Upholstery: Leather Max 96 dark brown. Legs: Walnut.
Pilot Stone Coffee Table. Table top: Grey Pietra marble.
Locus Bowl



Understated statement piece

Borge Mogensen's exceptional sense of proportions are at the core of this statement piece sofa. The Mogensen 2209. Capturing a key aspect of his design mantra, namely furniture with a calm aesthetic. Seen from the side, the quiet curve of the armrest and the gentle angle of the back are signature details that make this a simple, noble design. The Mogensen 2208 has all the same attributes in a 2-seater version.

For both sofa sizes, the ratio of foam to leather for the seat and back cushions has been carefully measured for comfort. Our variety of wood finishes for the base and vast array of leather options add a touch of cachet to this simple sofa series, found in embassies, minister's cabinets and upscale hotels around the world.



Model 2207
Lounge Chair
Page 152



Model 2202
Ottoman
Page 152



Model 2208
Sofa, 2 seater
L 128 cm D 82 H 84
SH 43 cm



Model 2209
Sofa, 3 seater
L 186 cm D 82 H 84
SH 43 cm

Borge Mogensen, 1963

Wood:
Oak soap, Oak oil, Oak light oil, Oak
black lacquered, Walnut oil.

Upholstery:
Limited selection of leathers and fabrics

Wood:
Oak soap, Oak oil, Oak light oil, Oak
black lacquered, Walnut oil.

Upholstery:
Limited selection of leathers and fabrics

PRODUCT SHEET DOWNLOAD
FREDERICIA.COM

Mogensen 2208 & 2209 Sofa



A legacy of lasting lifetimes

The Coupé Sofa has a high, cushioned back that extends upwards with a cushioned section for the neck, featuring wings on either side. The effect is an enveloping experience as a calm retreat in large, open spaces. Or for a formal setting in need of cosiness. Mogensen was always insistent on the highest quality materials with an uncompromising approach to comfort. And the Coupé Sofa is no exception.

Each sofa is made by hand, involving expert craftsmanship skills and the finest leather. The sturdy construction and subtle angle backwards allow for sitting upright while still relaxed. Seen from the side, the slight enclosure provided by the wings is meticulously measured to optimise a sense of intimacy. In this classic sofa with a legacy of lasting lifetimes.



Borge Mogensen, 1971

Model 2292
Coupé Sofa, 2 seater
L 154 cm D 89 H 106
SH 42 cm

Wood:
Oak soap, Oak oil, Oak light oil, Oak
black lacquered, Walnut oil.

Upholstery:
Limited selection of leathers and fabrics

PRODUCT SHEET DOWNLOAD
FREDERICIA.COM

Mogensen Coupé Sofa

Coupé Sofa
Upholstery: Leather Vegetal 90 Natural
Legs: Walnut oil



A restrained aesthetic

Borge Mogensen always aimed for a restrained aesthetic in designs with clarity and precision.

As the last sofa he designed before his untimely death in 1972, the Mogensen 2333 personifies his fondness for designs driven by vertical and horizontal lines. Emphasising the rectangular appearance of the 2333, the inner cushions sit upright and parallel to the armrests. Giving a strong graphic impression that's modest yet self-confident.

A range of leather and fabric options, including velvet, add a tactile dimension to a concept that continues to be one of Mogensen's most iconic.



Model 2334
Lounge Chair
Page 156



Model 2335
Sofa, 2½ seater
L 180 cm D 78 H 78
SH 43 cm



Model 2333
Sofa, 3 seater
L 207 cm D 78 H 78
SH 43 cm

Borge Mogensen, 1971/75

Wood:
Oak light oil, Oak black lacquered.
Upholstery:
Leather or fabric

Wood:
Oak light oil, Oak black lacquered.
Upholstery:
Leather or fabric

PRODUCT SHEET DOWNLOAD
FREDERICIA.COM

Mogensen 2333 & 2335 Sofa







Able to stand out or blend in

The Delphi is elegant with an expansive feeling. A sensual, streamlined design that captures the essence of simplicity, in a striking aesthetic able to stand out or blend in. The unique curve of the inner armrests at either end is a signature detail. In between is an uninterrupted space for sitting, stretching out or lounging. The low back is aligned with the arms, which gives the sofa a sleek sophistication. All of which has earned the Delphi its reputation as a contemporary classic with a cool factor.

With the Delphi Ottoman as its companion, the square shape and generous size allows you to create a chaise longue look. Use the ottoman as extra seating for guests or the kids. To place your computer, magazines and other essentials. Or to enjoy as a footrest. The Delphi concept is all about options, which makes it a favourite in hotels, lobbies and private homes.

Delphi was designed by Hannes Wettstein, considered one of the most innovative talents of his generation. He was a highly-regarded figure in the industry, known for surprisingly simple solutions that outlasted time. An award-winning Swiss designer whose focus spanned furniture, interior design and architecture to consumer products and communications. Wettstein died prematurely in 2008 but his designs continue to be appreciated around the world to this day.

					
Hannes Wettstein, 2007	Model 4510 Sofa L 205 D 85 H 66 cm SH 37 cm	Model 4511 Sofa L 240 D 85 H 66 cm SH 37 cm	Model 4512 Sofa L 325 D 85 H 66 cm SH 37 cm	Model 4516 Daybed L 205 D 85 H 37 cm SH 37 cm	Model 4508/4509 Ottoman Ø 85/120 cm SH 37 cm
Base: Brushed aluminium, Oak light oil.	Base: Brushed aluminium, Oak light oil.	Base: Brushed aluminium, Oak light oil.	Base: Brushed aluminium, Oak light oil.	Base: Brushed aluminium, Oak light oil.	
Upholstery: Leather or fabric	Upholstery: Leather or fabric	Upholstery: Leather or fabric	Upholstery: Leather or fabric	Upholstery: Leather or fabric	

PRODUCT SHEET DOWNLOAD
FREDERICIA.COM

A series of cushions to accompany the series available

Delphi Sofa

Delphi Sofa. Upholstery: Flord 151. Base: Brushed aluminium.
Spanish Chair. : Saddle leather, black. Wood: Smoked oak.
Tableau Coffe Table
Locus Bowl



Inventive in terms of options

Elegant in its expression, subtle in the details and inventive in terms of options, Delphi Elements is a stunning fusion of Swiss precision and Danish craftsmanship. The look is streamlined and stylish in an inviting, ergonomic design that's a contemporary classic.

Compared to typical sofas, Delphi Elements exudes sublime simplicity expressed in a modular, lifestyle solution. Featuring modules that allow you to create your own bespoke sofa set-up. Including the seat as a separate element to stand on its own or to combine into a chaise longue. As well as versions without armrests to create sofa clusters of various shapes. In order to achieve the tight, comfortable shape with no loose cushions, it involves expert upholstery skills.

Featuring a depth that's optimised for sitting or relaxing for hours. Delphi Elements is suitable for high-end hospitality venues, corporate environments, retail spaces and private residences.



Module 4501 End module, left or right L 120 D 85 H 66 SH 37 cm	Module 4514 End module, left or right L 180 D 85 H 66 SH 37 cm	Module 4513 Corner module L 85 D 85 H 66 SH 37 cm	Module 4502 Seat module L 120 D 85 H 66 SH 37 cm	Module 4506 Seat module L 85 D 85 H 66 SH 37 cm	Module 4505 Ottoman L 85 D 85 H 37 SH 37 cm	Module 4504 Ottoman L 120 D 85 H 37 SH 37 cm	Module 4503 Side module L 85 D 120 H 66 SH 37 cm
--	--	--	---	--	--	---	---

Hannes Wettstein, 2007

Base:
Brushed aluminium, Oak light oil.

Upholstery:
Leather or fabric

PRODUCT SHEET DOWNLOAD
FREDERICIA.COM



Configuration example A
Model 4504/4501(left)/4506/4501(right)
L 325 D 170 H 66 SH 37 cm



Configuration example B - Right
Model 4514(left)/4513/4501(right)
L 265 D 205 H 66
SH 37 cm

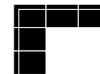

Configuration example C
Model 4503/4503/4501(left)/4502/4501(right)
L 360 D 255 H 66
SH 37 cm

Delphi Elements

Delphi Elements
Upholstery: Leather Omni 307 cognac
Base: Brushed aluminium





Delphi Elements. Upholstery: Leather Max 96 Dark Brown. Base: Brushed aluminium.
Ox Chair. Upholstery: Leather Max 96 Cognac. Base: Brushed chrome.
EJ66 Coffee Table. Table top: White Carrara. Base: Brushed Stainless steel.
Sequoia Pouf. Upholstery: Sheepskin.
Hydro Vase





Delphi Elements. Upholstery: Leather Max 95 Cognac. Base: Brushed aluminium.
Spanish Dining Chair. Upholstery: Natural saddle leather. Wood: Oak Soap.
Islet Coffee Table. Wood: Oak light oil.
Hydro Vase
Locus Bowl



Poetic yet purposeful

Spine Lounge Suite is a testament to simplicity as the ultimate form of exclusivity. Spine was originally designed for a Michelin-star restaurant in Copenhagen and has since expanded into an entire series with the same signature approach. Fluid lines form a solid, succinct design that exudes luxury from every angle.



Model 1710
Lounge Suite Chair
Page 190



Model 1711
Lounge Suite Chair Petit
Page 190



Model 1712
Suite Sofa 2 seater
L 160 D 81 H 71 cm
SH 41 cm



Model 1700
Daybed
L 190 D 85 H 45 cm
SH 35 cm

Space Copenhagen, 2011/16

Wood:
Oak lacquered, Black lacquered.

Upholstery:
Leather or fabric

Wood:
Oak lacquered, Black lacquered.

Upholstery:
Leather or fabric

PRODUCT SHEET DOWNLOAD
FREDERICIA.COM

Spine Lounge Sofa & Daybed





Spine Lounge Suite Sofa. Upholstery: Leather Omni 301 Black. Base: Black lacquered.
Piloti Stone Coffee Table. Table top: Grey Pietra.
Spanish Dining Chair. Saddle leather: Black. Base: Oak smoked and oiled.
Sequoia Pouf. Upholstery: Wool.



A beautifully composed classic

With the EJ315 Sofa, everything culminates in a beautifully composed and crafted design.

Given the rapid changes in the work environment, the EJ315 is appealing for innovative office concepts emerging around the globe. It also brings a touch of class to airport lounges, hospitality venues, reception areas and private residences.

Designed in 1975 by Erik Ole Jørgensen, the EJ315 is emblematic of Danish craftsmanship and attention to detail. Educated as a furniture upholsterer and subsequently as an architect, Jørgensen had an intuitive sense of tactility, also seen in his work with fabrics. The EJ315 is a perfect example.

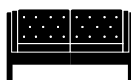

Model 1522
Sofa, 2 seater
L 153 D 77 H 81 cm
SH 43 cm

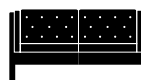

Model 1542
Sofa, 2½ seater
L 180 D 77 H 81 cm
SH 43 cm

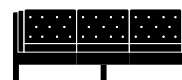

Model 1523
Sofa, 3 seater
L 210 D 77 H 81 cm
SH 43 cm

Erik Ole Jørgensen, 1975

Wood:
Oak soap, Oak light oil, Walnut oil,
Black lacquered.

Upholstery:
Leather or fabric

Wood:
Oak soap, Oak light oil, Walnut oil,
Black lacquered.

Upholstery:
Leather or fabric

Wood:
Oak soap, Oak light oil, Walnut oil,
Black lacquered.

Upholstery:
Leather or fabric

PRODUCT SHEET DOWNLOAD
FREDERICIA.COM

EJ315 Sofa

EJ315 Sofa
Upholstery: Luce 002
Legs: Oak Soap
BM67 Table
Wood: Oak Soap



EJ315. Upholstery: Clay 12. Wood: Oak light oil.
EJ66 Table. Table top: Black Marquina. Base: Brushed stainless steel.







EJ315 Sofa. Upholstery: Fiord 771.

EJ315 Sofa.
Upholstery: Flord 771
Legs: Walnut oil



Multi-purpose personified

Two of Denmark's most prolific designers from the last century, Borge Mogensen and Hans J. Wegner, were not only friends and school mates, they were also colleagues with a mutual passion for simplicity and functionality. While each one made a name for himself during the Danish Modernism movement, they often collaborated on a number of projects.

Back in 1945, the post-war optimism of WW2 ushered in new opportunities for designers to re-envision a fresh future. Denmark had already established itself as a platform for rising stars to showcase their ideas, with the annual exhibition by the Copenhagen Cabinetmakers' Guild. Mogensen and Wegner joined forces in creating their idea of "A Home for the Future".

They transformed their stand into a living room, where Mogensen presented a hybrid of a daybed and a chaise longue, with a hinged side. While the Spoke-Back Sofa was acclaimed for its innovative approach, it was considered too sophisticated for post-war tastes. It wasn't until 1963 that the sofa was put into industrial production. Exemplifying Mogensen's idea of a multi-purpose sofa.

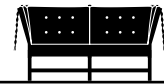

Borge Mogensen, 1945

Model 1789
Sofa, 2 seater
L 160/197 D 76,5 H 86 cm
SH 40 cm

Wood:
Oak soap, Oak black lacquered,
Oak white painted.

Upholstery:
Leather or fabric

PRODUCT SHEET DOWNLOAD
FREDERICIA.COM

The Spoke-Back Sofa

Spoke-Back Sofa
Upholstery: Vidar 1511
Wood: Oak Light Oil

Piloti
Wood: Oak Light Oil





Spoke-Back Sofa. Upholstery: Cotil 53938. Wood: Oak soap.



Masterful sense of materials

In 1955, when Andreas Graversen acquired Fredericia, he did so with one stipulation. That the production of furniture would be aligned with the vision of Børge Mogensen, who Graversen had appointed as Head of Design based on Mogensen's pure, honest, unpretentious style. The No. 1 Sofa was the first sofa series that Mogensen designed for Fredericia, and it marked the start of a close collaboration.

Mogensen imbued the No. 1 Sofa with his masterful sense of materials and proportions, emphasising the horizontal and vertical lines, with clean angular armrests. The tightly upholstered wooden frame is softened by loose, interchangeable buttoned cushions. It's all in keeping with Mogensen's quest to create functional furniture that would enhance people's everyday lives.

Børge Mogensen, 1955



Model 2002
Sofa, 2 seater
L 143 D 86 H 83 cm
SH 42 cm



Model 2003
Sofa, 3 seater
L 206 D 86 H 83 cm
SH 42 cm

Wood:
Oak soap, Oak light oil,
Oak black lacquered.

Upholstery:
Leather or fabric

Wood:
Oak soap, Oak light oil,
Oak black lacquered.

Upholstery:
Leather or fabric

PRODUCT SHEET DOWNLOAD
FREDERICIA.COM

No.1 Sofa

No. 1 Sofa
Upholstery: Sunniva 242
Legs: Oak light oil

Piloti Table
Wood: Oak light oil



The culmination of contrast and cohesion

The JG Sofa is the culmination of contrast and cohesion, with a touch of informality. Conducive to virtually any interior, even where there's a limited amount of space.

Designed by Jørgen Gammelgaard in 1979, the open structure is punctuated with rounded armrests on both sides, resulting in a roomy sofa that appears somewhat compact. The rounded ends make the JG Sofa easy to get around and uniquely compatible with other shaped furniture. The contrast continues with the soft cushions juxtaposed against the minimalistic wooden frame.



Jørgen Gammelgaard, 1979

Model 6522
Sofa, 2 seater
L 142 cm D 78 H 71
SH 41 cm

Model 6523
Sofa, 3 seater
L 202 cm D 78 H 71
SH 41 cm

Base:
Oak light oil, Oak light oil w. ntural
leather strap, Walnut oil, Metal black,
Stainless steel

Upholstery:
Leather or fabric

Base:
Oak light oil, Oak light oil w. ntural
leather strap, Walnut oil, Metal black,
Stainless steel

Upholstery:
Leather or fabric

PRODUCT SHEET DOWNLOAD
FREDERICIA.COM

JG Sofa

JG Sofa
Upholstery: Fiord 961
Base: Walnut oil





JG Sofa. Upholstery: Leather Vegeta 90 Natural. Base: Oak light oil.
Piloti Stone Table. Stone: Grey pietra marble.
JG Folding Stool. Base: Brushed stainless steel. Seat: Leather Max 95, Cognac.



Open yet embracing

Savannah is a sofa series that celebrates classic craftsmanship, natural materials and a mix of textures. It's comprised of a structure made from solid wood, wrapped in leather, which creates a beautiful frame that extends from each side all the way around the back of the sofa. It's an open yet embracing sofa by Swedish designer Monica Förster, known for her strong sense of form, colour and detail, along with her passion for new materials and technology.

Förster is an advocate of traditional craft techniques, which she incorporates in her process of inventing and renewing typologies within industrial, furniture and object design.



Model 8805
Lounge Chair
Page 212



Model 8801
Lounge Chair
Page 208



Model 8802
Sofa, 2 seater
L 180 D 84 H 80 cm
SH 42 cm

Monica Förster, 2015

Wood:
Oak light oil, Black lacquered.

Saddle leather on frame:
Black or cognac

Upholstery (cushions):
Fabric

PRODUCT SHEET DOWNLOAD
FREDERICIA.COM

Savannah Sofa



In search of serenity

Calmo echoes our heritage of sofa expertise in a fresh typology, from Portuguese designer Hugo Passos. A firm believer that "designs must serve their purpose and, more than anything, they should bring you pleasure." The outcome is an archetypal sofa that embraces our rational approach to forms that follow function – balanced by subtle styling that gives the series even more international appeal.

Referencing our legacy of sofa design, the well-conceived construction of Calmo ensures our decades of knowledge, ensuring the utmost comfort for decades to come. In fact, the seating comfort of Calmo has undergone a thorough analysis, incorporating the most modern ways people use sofas today.

The depth of the seat is calibrated to make the sofa conducive for working on a laptop as well as socialising, with enough space to provide a comfortable, soothing experience. At the same time, the sofa offers enough support for a seated conversation, reclining and relaxing.

Calmo is impeccably crafted in line with our sofa philosophy, where the frame features tight upholstery, while the loose filling cushions add contrast and a casual feel to the formality of the sofa. From a practical perspective, when upholstered in fabric, the cushions have fabric on both sides. Adding to the longevity of the look, the cushions can be flipped over for a more even patina over time.



Model 5652
Sofa, 2 seater 95
L 200 D 90 H 75,5 cm
SH 41 cm



Model 5653
Sofa, 3 seater 95
L 295 D 90 H 75,5 cm
SH 41 cm



Model 5655
Sofa, 3 seater Chaise 95
L 295 D 155,5 H 75,5 cm
SH 41 cm

Wood:
Oak lacquered, Smoked oak stained.

Metal base:
Black, Matt chrome.

Upholstery:
Leather or fabric

Wood:
Oak lacquered, Smoked oak stained.

Metal base:
Black, Matt chrome.

Upholstery:
Leather or fabric

Wood:
Oak lacquered, Smoked oak stained.

Metal base:
Black, Matt chrome.

Upholstery:
Leather or fabric



Model 5622
Sofa, 2 seater 80
L 170 D 90 H 75,5 cm
SH 41 cm



Model 5623
Sofa, 3 seater 80
L 250 D 90 H 75,5 cm
SH 41 cm



Model 5625
Sofa, 3 seater Chaise 80
L 250 D 155,5 H 75,5 cm
SH 41 cm

Wood:
Oak lacquered, Smoked oak stained.

Metal base:
Black, Matt chrome.

Upholstery:
Leather or fabric

Wood:
Oak lacquered, Smoked oak stained.

Metal base:
Black, Matt chrome.

Upholstery:
Leather or fabric

Wood:
Oak lacquered, Smoked oak stained.

Metal base:
Black, Matt chrome.

Upholstery:
Leather or fabric

PRODUCT SHEET DOWNLOAD
FREDERICIA.COM

Calmo Sofa

Calmo Sofa
Upholstery: Ruskin 10
Base: Black

Piloti Table
Wood: Black





Calmo Sofa. Upholstery: Ruskin 10. Base: Black.
Spanish Chair. Saddle leather: Black. Base: Smoked oak oil.
Tableau Coffe Table
Magazine Table. Wood: Black lacquered.





Calmo Sofa. Upholstery: Ruskin 10. Base: Black.
Piloti Stone Coffee Table. Table top: Grey Pietra marble.



Minimalism reimaged

Stylised curves create a tranquil mood in a sofa that ventures into a new vernacular for minimalism reimaged.

A beautiful balance of aesthetics and execution that stays true to its name - a contraction of the Japanese 'ko' and 'nami' which means 'little wave'. The sensual shape of each cushion is like a silent wave on the slim frame, echoed in the soft curve of the inner armrests.

Together with the back cushions gently angled back, Konami was conceived as a welcoming gesture for you to take a seat, relax and unwind. Adding to the ethereal feeling are the slim steel legs that gracefully elevate the sofa up from the floor.



Damian Williamson, 2019

Model 4952
Sofa, 2 seater
L 188 D 104 H 71 cm
SH 42 cm

Model 4953
Sofa, 3 seater
L 277 D 104 H 71 cm
SH 42 cm

Model 4962
Sofa, 2½ seater
L 235 D 104 H 71 cm
SH 42 cm

Base:
Black, Brushed stainless steel.

Upholstery:
Limited selection of fabrics

Base:
Black, Brushed stainless steel.

Upholstery:
Limited selection of fabrics

Base:
Black, Brushed stainless steel.

Upholstery:
Limited selection of fabrics

PRODUCT SHEET DOWNLOAD
FREDERICIA.COM

Konami Sofa







An enclave of intimacy

Balancing classic and contemporary with an element of the unexpected, GamFratesi passionately pursue projects that are subtly embedded with a story. Drawing on their Danish/Italian roots as architects to create well-crafted, conceptual ideas that embrace contrasts.

For their Haiku Sofa, inspiration came from the Japanese genre of poetry by the same name. With Haiku poetry, the aim is to use very few words to convey a myriad of emotions and associations. To capture the essence of an experience with succinct simplicity. Similarly, GamFratesi's Haiku Sofa is designed with just a few lines to convey a feeling that's open yet encompassing.

The clear outline of the outer shell is juxtaposed against the soft interior, providing an intimate sense of acoustic and visual privacy. At the same time, the singular seat cushion, loose pillows and upholstered back add an ample feeling of comfort.

To highlight the contrast between the outer shell and the interior is the option to mix or match a wide variety of fabrics. To complete the picture, the delicate, discrete legs give the impression that the sofa is almost hovering above the ground.

In large, expansive spaces, the Haiku Sofa introduces a cosy sense of comfort, where you can create enclaves of intimacy with clusters of the larger high-back versions of Haiku. For the hospitality sector and retail environments, the smaller high-back version, will enhance a feeling of privacy.



GamFratesi, 2012

Model 1632
Sofa, 2 seater
L 156 D 88 H 103 cm
SH 44,5 cm

Model 1633
Sofa, 3 seater
L 228 D 88 H 103 cm
SH 44,5 cm

Base:
Black

Upholstery:
Leather or fabric.
Front side can only be upholstered
in fabric.

Base:
Black

Upholstery:
Leather or fabric.
Front side can only be upholstered
in fabric.

PRODUCT SHEET DOWNLOAD
FREDERICIA.COM

Haiku Sofa

Haiku Sofa
Upholstery: Remix 143
Base: Black









Haiku Sofa. Upholstery: Harald 212 & Sonar 112. Base: Black.



Symmetry & simplicity

Clear, clean lines set the tone for the EJ280 Sofa, a modern, minimalistic design that's all about lounging with ease. Featuring rather large, long, generous cushions that trigger the desire to relax. Add the optional ottoman as an extension of the sofa and to create a chaise longue look, and you have a classy sofa well-suited for countless scenarios. Drawing on our years of experience in sofa design and production, the EJ280 is a beautiful example of uncompromising comfort.

Visually, the linear structure is in contrast to the more relaxed, soft interior. The result is a simple, harmonious aesthetic. A sofa that's versatile enough to create a cosy ambience at home. Spacious enough to hold informal meetings at work. Or as a statement piece in a hospitality venue.

				
Erik Jørgensen Studio, 2010	Model 8050 Ottoman 86 L 86 D 68 H 42 cm	Model 8060 Ottoman 100 L 100 D 68 H 42 cm	Model 8052 2 seater, 86 cm cushions L 212 D 90 H 73 cm SH 42 cm	Model 8062 2 seater, 100 cm cushions L 240 D 90 H 73 cm SH 42 cm
	Sledge base: Brushed chrome	Sledge base: Brushed chrome	Sledge base: Brushed chrome	Sledge base: Brushed chrome
	Seperate legs: Brushed aluminium	Seperate legs: Brushed aluminium	Seperate legs: Brushed aluminium	Seperate legs: Brushed aluminium
	Wood: Oak soap	Wood: Oak soap	Wood: Oak soap	Wood: Oak soap
	Upholstery: Leather or fabric	Upholstery: Fabric	Upholstery: Leather or fabric	Upholstery: Leather or fabric
	PRODUCT SHEET DOWNLOAD FREDERICIA.COM			

EJ280 Sofa

ERIKJØRGENSEN

EJ280 Sofa.
Upholstery: Njord363607
Base: Brushed chrome





EJ280 Sofa. Upholstery: Leather Primo 74 Umbra Grey, Base: Brushed aluminium.
Islets Coffee Table. Wood: Oak light oil.
Pon Table: Wood: Oak oil.
Mono Pouf. Upholstery: Grand Linen Natural.



EJ280 Sofa. Upholstery: Clay 12. Base: Brushed chrome.
Islets Coffee Table. Wood: Oak light oil.
Post Table. Wood: Oak light oil.
BM61 Chair. Cane wicker: Natural. Wood: Oak oil.
Mono Pouf. Upholstery: Leather Vegeta 90 Natural.
Locus Bowl





A corner sofa conceived with comfort

Straight, definitive lines merge with soft, large cushions in a slender sofa concept that's easy to envision anywhere. The EJ280 Elements is all about simplicity and versatility. Building on a classic frame with curved details, it's a corner sofa conceived with comfort, opening up all kinds of possibilities for placement.

Given its classy yet casual appearance, EJ280 Elements has ample seating for all kinds of co-working scenarios. Hotel lobbies. Retail spaces. And private homes. The wooden base adds a down-to-earth feeling, with a choice of fabrics that enhance a sense of softness. Style it up for more exclusive venues and you still have a sofa that retains its purity.



Erik Jørgensen Studio,
2018

Model 8099
Corner module
L 98 D 98 H 80 cm
SH 42 cm

Model 8066
Seat module, 1 seater 100
L 100 D 90 H 80 cm
SH 42 cm

Model 8057
Seat module, 2 seater 86
L 172 D 90 H 80 cm
SH 42 cm

Model 8067
Seat module, 2 seater 100
L 200 D 90 H 80 cm
SH 42 cm

Sledge base:
Brushed chrome

Separate legs:
Brushed aluminium

Wood:
Oak soap

Upholstery:
Fabric

PRODUCT SHEET DOWNLOAD
FREDERICIA.COM

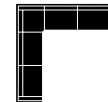

Modular example B
Models:
8057 L / 8099 / 8057 R
L 290 D 290 H 80 cm
SH 42 cm

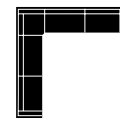

Modular example C
Models:
8067 L / 8099 / 8067 R
L 318 D 318 H 80 cm
SH 42 cm

EJ280 Elements

ERIKJØRGENSEN



Everyday informality

The EJ288 is a casual sofa with a Scandinavian vibe. Adding to its air of informality is an unconventional wooden frame coupled with large, soft cushions. The EJ288 boasts numerous fine-tuned details, such as the double curve for the armrests as a signature part of the design. Where the gentle curve of the frame at each end is mirrored in the inner arm cushion, resulting in extra comfort. In a nonchalant look that's open and inviting.

Careful attention has gone into amplifying the comfort, so the sofa is equally comfortable sitting in an upright position or leaning back, relaxing and socialising. Soft yet supportive, comfortable yet surprisingly sturdy, the EJ288 is a welcome addition to both the private and corporate sectors.



Erik Jørgensen Studio, 2018

Model 8862
Sofa 3 Seater
L 232 D 90 H 78 cm
SH 44 cm

Base:
Brushed aluminium, Oak lacquered,
Oak soap.

Upholstery:
Leather or fabric

PRODUCT SHEET DOWNLOAD
FREDERICIA.COM

EJ288 Sofa

ERIKJØRGENSEN

EJ288 Sofa
Upholstery: Linara 434
Legs: Oak lacquered



EJ288 Sofa. Upholstery: Linara 434.
Sequoia Pouf. Upholstery: Sheepskin.
J16 Stool. Paper cord. Natural. Wood: Oak soap.
Islets Coffee Table. Wood: Oak light oil.
Locus Bowl
Hydro Vase





The sofa that's a lounge

The EJ295 Chaise Sofa is elegant yet informal with an understated aesthetic. It features an array of refined details, which draw on our extensive upholstery skills. Such as the soft contours of the seat cushions that provide maximum comfort for total relaxation, along with loose, reversible pillows.

A multi-purpose design that's part lounge sofa, part daybed, the EJ295 Chaise Sofa is ideal for upscale private residences, a spacious country home and the like. Whether as a stand-alone centrepiece in a mansion or in the corner of a spacious interior to create a sense of intimacy.

Erik Jørgensen Studio, 2016/18



Model 2945
Chaise Sofa 76
L 240 D 168 H 70 cm
SH 40 cm

Model 2955
Chaise Sofa 86
L 270 D 168 H 70 cm
SH 40 cm

Base:
Chrome, Dark grey.

Upholstery:
Fabric

Available with right or left hand
chaise longue

Base:
Chrome, Dark grey.

Upholstery:
Fabric

Available with right or left hand
chaise longue

PRODUCT SHEET DOWNLOAD
FREDERICIA.COM

EJ295 Chaise Sofa

ERIKJØRGENSEN

EJ295 Chaise Sofa
Upholstery: Bardal 780
Base: Dark grey
Tableau Coffee Table
Hydro Vase



With effortless ease

Part of what makes the EJ220 Sofa a welcome addition to any scenarios is its unassuming appearance. Long, slender lines form the framework for a tranquil design where you can relax with effortless ease. Resulting in a quiet sofa that you can incorporate into any type of interior of décor.

The soft cushions in contrast to the rigid lines of the sofa's back and base provide a high level of comfort, reflecting our decades of experience with sofas and expertise with ergonomics. Even though it was launched in the early 1970s, the EJ220 Sofa is a timeless design appreciated for its uncomplicated approach to comfort.



Erik Jørgensen, 1970

Model 2042
Sofa, 2 seater 76
L 163 D 86 H 73 cm
SH 42 cm

Model 2052
Sofa, 2 seater 86
L 185 D 86 H 73 cm
SH 42 cm

Model 2033
Sofa, 3 seater 67
L 212 D 86 H 73 cm
SH 42 cm

Model 2062
Sofa, 2 seater 100
L 212 D 86 H 73 cm
SH 42 cm

Base:
Brushed chrome, Oak lacquered,
Oak soap.

Upholstery:
Leather or fabric

Base:
Brushed chrome, Oak lacquered,
Oak soap.

Upholstery:
Leather or fabric

Base:
Brushed chrome, Oak lacquered,
Oak soap.

Upholstery:
Leather or fabric

Base:
Brushed chrome, Oak lacquered,
Oak soap.

Upholstery:
Leather or fabric

PRODUCT SHEET DOWNLOAD
FREDERICIA.COM

EJ220 Sofa

ERIKJØRGENSEN

EJ220 Sofa. Upholstery: Ruskin 10. Base: Brushed chrome.
EJ66 Table. Table top: White Carrara. Base: Brushed stainless steel.
Ditzel Lounge Chair. Upholstery: Sheepskin. Legs: Walnut laquered.
Hydro Vase



Unadorned expression

Given its slender lines and unadorned expression, EJ220 Elements is arguably a sofa concept for everyone. It's an evolution of the EJ220 Sofa with an extra seat in the corner and a sofa seat just perpendicular. One united entity in a corner sofa that's easy to look at and live with. The back cushions are tilted just a bit to make sitting back as comfortable as sitting upright.

That's in addition to our in-depth sofa expertise embedded inside. To punctuate the design, there's a smaller, soft cushion on either end just inside the arms. A subtle detail adding a touch of warmth to a pure design that's always welcoming. Suitable for corporate settings, lobbies and living rooms.



Erik Jørgensen, 1970

Model 2099
Corner module
L 85 D 85 H 80 cm
SH 42 cm

Model 2066
Seat module 1 seater 100
L 100 D 85 H 80 cm
SH 42 cm

Model 2037
Seat module 2 seater 67
L 133 D 85 H 80 cm
SH 42 cm

Model 2047
Seat module 2 seater 76
L 150 D 85 H 80 cm
SH 42 cm

Base:
Brushed chrome, Oak lacquered,
Oak soap.

Upholstery:
Leather or fabric

Base:
Brushed chrome, Oak lacquered,
Oak soap.

Upholstery:
Leather or fabric

Base:
Brushed chrome, Oak lacquered,
Oak soap.

Upholstery:
Leather or fabric

Base:
Brushed chrome, Oak lacquered,
Oak soap.

Upholstery:
Leather or fabric



Model 2057
Seat module 2 seater 86
L 173 D 85 H 80 cm
SH 42 cm

Model 2067
Seat module 2 seater 100
L 200 D 85 H 80 cm
SH 42 cm

Model 2038
Seat module 3 seater 67
L 200 D 85 H 80 cm
SH 42 cm

Base:
Brushed chrome, Oak lacquered,
Oak soap

Upholstery:
Leather or fabric

Base:
Brushed chrome, Oak lacquered,
Oak soap

Upholstery:
Leather or fabric

Base:
Brushed chrome, Oak lacquered,
Oak soap

Upholstery:
Leather or fabric

PRODUCT SHEET DOWNLOAD
FREDERICIA.COM

EJ220 Elements

ERIKJØRGENSEN

EJ220 Elements
Upholstery: Bardal 220
Base: Oak Soap

EJ66 Table
Table top: White Carrara
Base: Brushed stainless steel



Tables

A table is a platform for sharing ideas, opportunities, emotions and opinions. It's rare to see a conference room without a table. A meeting room with just chairs. Or a dining room with no place to dine. A table is an essential element that allows people to work, study and socialise. It can be the focal point in an executive office or an informal place to collaborate. Part of a meet and greet exhibition space or a statement piece in a retail or commercial venue.

BM71 Library Table	306
C18 Table	308
6284 Table	310
6286 & 6386 Table	312
Islets Dining Table	316
Plan Table	318
JG Table	324
Taro Table	326
Post Table	330
Ana Table	334
Mesa Table	338

Every detail has a purpose

Borge Mogensen's Library Table was his initial debut at the Cabinetmakers Guild Exhibition in 1958. The pure lines and open construction are emblematic of his approach to designs driven by function. Where every detail has a precise purpose that correlates to its use. By raising and securing the hinged leaves at either end, the length of the table could be doubled. When not in use, the hinged leaves fold down to hang vertically. Resulting in a clean, rectangular profile of a practical, multi-purpose design crafted in oak.

The concept was inspired by the English gateleg table dating back to the Baroque period. But it was Mogensen's refined visual expression and elimination of anything unnecessary, which contributed to its iconic status. Modest in appearance and meticulously proportioned, the Library Table is perfectly suited for executive offices, conference rooms, libraries, law offices, galleries and private homes.



Borge Mogensen, 1958

Model 6271
Dining Table
L 131/189/252 W 93 H 72 cm

Wood:
Oak lacquered, Oak oil.

PRODUCT SHEET DOWNLOAD
FREDERICIA.COM

BM71 Library Table

Library Table
Wood: Oak oil
BM61/BM62 Chair
Cane wicker: Natural
Wood: Oak oil



Functionally-driven

Borge Mogensen's mission was to create simple, functionally-driven furniture for everyday use. The C18 Table from 1947 is an ideal example. The clean lines are inspired by the utilitarian approach behind traditional Shaker furniture.

The opportunity to extend the table by 40 cm at each end allows you to transform the C18 from a dining table for the family to a dinner party with numerous guests. Or from a desk in a home office to a multi-purpose work station with colleagues in a corporate setting.

Borge Mogensen, 1947



Model 6290
Dining Table
L 180 W 90 H 73 cm

Model 6293
Dining Table
L 220 W 90 H 73 cm

Wood:
Oak soap, Oak light oil,
Smoked oak oil.

Wood:
Oak soap, Oak light oil,
Smoked oak oil.

PRODUCT SHEET DOWNLOAD
[FREDERICIA.COM](https://www.fredericia.com)

C18 Table

C18 Table
Wood: Oak soap
J39 Chair
Paper cord: Natural
Wood: Oak soap



Sense of proportion

Borge Mogensen designed a series of tables that would be practical and durable for generations. The 6284 Table from 1958 embodies his desire for longevity in a restrained aesthetic, made from the finest selection of solid oak available in a variety of finishes.

The 6284 has a sober, sturdy simplicity that makes it an appealing choice as a dining table for restaurants, work settings and private residences.

With the added advantage of additional leaves that extend the table top by 40 cm at each end.



Borge Mogensen, 1958

Model 6284
Dining Table
L 180 W 90 H 73 cm

Wood:
Oak soap, Oak light oil,
Smoked oak oil.

PRODUCT SHEET DOWNLOAD
FREDERICIA.COM

6284 Table

6284 Table. Wood: Oak light oil.
Seborg Chair. Wood: Oak black lacquered. Base: Black.



Shaker style re-defined

Pure shapes and a humble appearance were key attributes of Borge Mogensen's designs. They were also the guiding principles behind the American Shaker movement, which was Mogensen's source of inspiration for the 6286 Table from 1964, followed by the longer 6386 variant.

Allowing the texture and character of the material, in this case a premium selection of oak, to be the focal point. The use of wood and craftsmanship involved in the making of the 6286 adds an element of authenticity to group dining, conference rooms, exhibition and commercial spaces, as well as private homes.

Borge Mogensen, 1964



Model 6286
Dining Table
L 195 W 97,5 H 73 cm

Model 6386
Dining Table
L 245 W 97,5 H 73 cm

Wood:
Oak soap, Oak light oil,
Smoked oak oil.

Wood:
Oak soap, Oak light oil,
Smoked oak oil.

PRODUCT SHEET DOWNLOAD
FREDERICIA.COM

6286 Table 6386 Table

6286 Table
Wood: Oak light oil
BM61 Chair
Wicker: Natural
Wood: Oak oil
Locus Bowl





6386 Table. Wood: Oak oil.
BM61 Chair. Cane wicker: Natural. Wood: Oak oil.
Locus Bowl



Contrasts come together

Designer Maria Bruun brings a brilliant sense of equilibrium to the Islets Dining Table. A cohesive design that juxtaposes a slim, round table top supported by solid, cylindrical oak legs. As a result, the impression is strong yet still subtle in a sculptural concept that showcases the innate beauty and enduring integrity of oak.

The name Islets takes its inspiration from several small, man-made islands in a Copenhagen borough called Christianhavn. A vibrant, urban archipelago structurally supported by a foundation of oak pillars. Enjoy a harmonious design able to add warmth and originality to any dining experience.



Maria Bruun, 2020

Model 6775
Dining Table
Ø 120 H 73 cm

Wood:
Oak light oil

PRODUCT SHEET DOWNLOAD
[FREDERICIA.COM](https://www.fredericia.com)

Islets Dining Table

BM61 Chair
Webbing: Linen webbing Natural
Wood: Oak oil

Islets Dining Table
Wood: Oak light oil

Silhouette Mirror
Wood: Walnut

Locus Bowl



An intriguing graphic aesthetic

The plan tables are built on a strong and sturdy base that allows for a wide range of tabletops. The tabletop has generously rounded edges that are friendly to get around. Though simple at first glance, the subtle craftsmanship details, such as the cable tray cover in cognac leather, bring a heritage feel to the table.

The leather is leftovers from the production of the Børge Mogensen's iconic Spanish Chair. Plan Table is designed to fit the design ethos of the Plan Chair, but it is suitable for most chair designs, from classic to contemporary.



Edward Barber & Jay Osgerby, 2022

Model 6631
Plan Table Fixed
L 200 W 100 H 73 cm

Model 6632
Plan Table Extensasble
L 200 / 260 W 100 H 73 cm

Model 6569
Plan Table Modular
L (length is customisable
depending on which and how
many of the eight different
modules are chosen) W 100
/120 H 73 cm

Steel Frame:
Black, Brushed steel, Modernist Green,
Bordeaux.

Table top:
Oak lacquered, Oak soap treated,
Oak oil treated, Oak light oil, Smoked
oak oiled, Nano laminate Black, Really
Cotton Cream.

Steel Frame:
Black, Brushed steel, Modernist Green,
Bordeaux.

Table top:
Oak lacquered, Oak soap treated,
Oak oil treated, Oak light oil, Smoked
oak oiled, Nano laminate Black, Really
Cotton Cream.

Steel Frame:
Black, Brushed steel, Modernist Green,
Bordeaux.

Table top:
Oak lacquered, Oak soap treated,
Oak oil treated, Oak light oil, Smoked
oak oiled, Nano laminate Black, Really
Cotton Cream.

PRODUCT SHEET DOWNLOAD
FREDERICIA.COM

Plan Table

Plan Table
Base: Black
Tabletop: Oak lacquered

Plan Chair
Base: Black
Seat and back: Oak lacquered

Plan Chair
Base: Black
Seat and back: Black lacquered



Plan Chair
Base: Black
Seat and back: Oak lacquered.

Plan Table Modular
Base: Black
Top: Really Cotton Cream





An intriguing graphic aesthetic

The JG Table expresses designer Jørgen Gammelgaard's desire to create a simple, elegant design with a supportive structure that would not limit the seating around the table. To achieve this, the legs form a unique structure that does not interfere with the corners of the table underneath. Providing remarkable stability, as well as an intriguing graphic aesthetic.

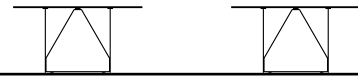

Jørgen Gammelgaard, 1984

Model 6568
Dining Table
Ø 140 H 72 cm

Model 6569
Dining Table
L 140 W 140 H 72 cm

Frame:
Black powder coated steel,
Brushed stainless steel.

Frame:
Black powder coated steel,
Brushed stainless steel.

Table top:
Grey linoleum with natural ash edge,
Black linoleum with black oak edge,
White Carrara, Black Marquina,
Ivory Quartzite.

Table top:
Grey linoleum with natural ash edge,
Black linoleum with black oak edge,
White Carrara, Black Marquina,
Ivory Quartzite.

PRODUCT SHEET DOWNLOAD
FREDERICIA.COM

JG Table

JG Table
Frame: Brushed stainless steel
Top: Ivory Quartzite

The Spanish Dining Chair
Upholstery: Natural saddle leather
Wood: Oak soap



JG Table
Frame: Brushed stainless steel
Top: Grey linoleum with natural ash
edge

J39 Mogensen Chair
Wood: Oak light oil
Seat: Natural paper cord

Canvas Chair:
Canvas: Natural
Wood: Oak soap





Akin to a plank table

Useful, understated, responsible design is an ongoing theme for Jasper Morrison. Seen in his focus on contemporary archetypes reduced to their functional essentials, as part of his definition of good design.

The Taro Tables exude the natural appeal of oak, which will patinate beautifully over time, in a simple design that's unassuming yet appealing. Whether round or rectangular, for residential dining or corporate meetings, Taro commands attention with its solidity and stunning natural patterns of the wood grain.



Model 6119
Dining/Café Table
Ø 90 H 73 cm



Model 6121
Dining Table
Ø 120 H 73 cm

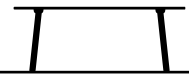

Model 6106
Dining Table
L 220 W 93,5 H 73 cm

Jasper Morrison, 2016

Wood:
Oak soap, Oak light oil,
Smoked oak oil.

Wood:
Oak soap, Oak light oil,
Smoked oak oil.

Wood:
Oak soap, Oak light oil,
Smoked oak oil.

PRODUCT SHEET DOWNLOAD
FREDERICIA.COM

Taro Table

Taro Table.
Wood: Smoked oak oil
J39 Chair
Paper cord: Black
Wood: Oak black lacquered



Yksi Chair
Upholstery: Leather Primo 75 Cognac
Wood: Oak lacquered

Taro Table
Wood: Oak soap

Magazine Table
Wood: Oak lacquered





Only what's essential

The Post Table illustrates the idea of eliminating anything extra to solely focus on the essential. A classic design expressed with modern minimalism, the table is made from solid oak, featuring loads of leg room in the wide space between the legs on either end. The table top is available in three lengths, supported by the same cylindrical legs as the Post Chair.

Like the chairs, its minimalist design makes it suitable for dining or meetings in a corporate, private or hospitality settings. For designer Cecilie Manz, her design process starts with examining the purpose of a piece of furniture. By stripping the concept down to only what's necessary, the form that emerges from the function is pure and purposeful.



Cecilie Manz, 2020

Model 6438
Dining Table
L 225 W 100 H 73 cm

Model 6440
Dining Table
L 265 W 100 H 73 cm

Model 6442
Dining Table
L 320 W 100 H 73 cm

Wood:
Oak soap, Oak light oil.

Wood:
Oak soap, Oak light oil.

Wood:
Oak soap, Oak light oil.

PRODUCT SHEET DOWNLOAD
[FREDERICIA.COM](https://www.fredericia.com)

Post Table

Post Table
Wood: Oak soap







Sleek & discrete

The Ana Table is a dining table with a solid wood frame and an extendable table top. Underneath is a butterfly folding system, providing a discrete place to store the leaves of the table when not in use. Conceived with agility in mind, the easy-to use extension mechanism makes the Ana Table an enduring design that allows for up to 12 guests. The choice of table tops includes nano laminate versions in a variety of colours, each with a different type of oak edge as an accent.

Resulting in a harmonious mix of materials and hues, as well as a tactile experience of the smooth matt finish. Given the subtleties of the design, from the edges in solid wood to the elegance of the extendable table top, it's an extremely diverse table that could easily work in combination with any type of chair. For a multitude of uses, whether at home in a private setting or in a corporate milieu for business meetings.

Arde, 2018



Model 6491
Dining Table
L 180/280 W 95 H 73 cm



Model 6490
Dining Table
L 220/320 W 95 H 73 cm

Variants:
White nano laminate table top /
Oak soap base and edges.

Almond nano laminate table top /
Oak soap base and edges.

Almond nano laminate table top /
Smoked oak oil-stained base and
edges.

Black nano laminate table top /
Smoked oak oil-stained base and
edges.

Variants:
White nano laminate table top /
Oak soap base and edges.

Almond nano laminate table top /
Oak soap base and edges.

Almond nano laminate table top /
Smoked oak oil-stained base and
edges.

Black nano laminate table top /
Smoked oak oil-stained base and
edges.

PRODUCT SHEET DOWNLOAD
FREDERICIA.COM

Ana Table

Ana Table
Table top: White nano laminate
Base: Oak soap

J64 Chair
Wood: Black ash





Ana Table. Table top: Almond nano laminate. Base: Smoked oak.
Trinidad. Wood: Grey oak stained. Base: Flint.



For virtually any venue

A simple, versatile table that blends seamlessly into any décor, Mesa gives the impression of a slim line that appears across a room. Boasting a thin, linoleum table top in contrast to the soft curves of the aluminium frame. Attached to the frame are the legs, which are placed at the outermost edges of the table. Allowing for the most leg room possible for any type of chair imaginable.

Whether as a desk, dining table or conference table, Mesa is a discrete, durable solution that's easy to assemble and disassemble. In a streamlined aesthetic that makes it a natural choice for virtually any situation. Adding a tranquil sense of simplicity even to the busiest of environments.



Welling/Ludvik, 2013	Model 4616 Table - dining, counter or bar height L 160 W 90 H 73	Model 4618 Table - dining, counter or bar height L 180 W 90 H 73	Model 4620 Table - dining or counter height L 200 W 100 H 73	Model 4625 Table - dining height L 240 W 100 H 73 cm	Model 4630 Table - dining height L 300 W 120 H 73 cm
----------------------	---	---	--	--	--

Table top:
Black linoleum

Frame:
Black

Table top:
Black linoleum

Frame:
Black

Table top:
Black linoleum

Frame:
Black

Table top:
Black linoleum

Frame:
Black

Table top:
Black linoleum

Frame:
Black

PRODUCT SHEET DOWNLOAD
FREDERICIA.COM

Mesa Table

Mesa Table
Table top: Black Inoleum
Frame: Black

Pato Executive
Upholstery: Leather Max 93 Indian Red
Base: Polished aluminium





Mesa Table. Table top: Black linoleum. Frame: Black.

Mesa Table
Table top: Black Inoleum
Frame: Black

Pato Office Chair
Upholstery: Rime 641
Base: Black



Coffee Tables





Business settings, reception areas, hotel lobbies, lounges and living rooms. Wherever there's an opportunity for people to truly connect, there's a coffee table. It can be the centrepiece in a room. A practical place for your laptop in a café or co-working scenario. Or simply a cosy place to gather friends together.

Pon Table	346
Insula Table	348
Pal Table	352
Islets Table	354
Piloti Table	356
Piloti Stone Table	358
Piloti Alu Table	360
Tableau Coffee Table	362
EJ66 Coffee Table	364
Wegner Ox Table	366

Various visual expressions

Pon is designed to be an alternative to the classic coffee table. Instead of one table that takes up space, the compact shape and variety of sizes opens up a wide range of visual expressions. From creating a cluster of tables in different heights to creating contrast with various wood finishes to using Pon as stand-alone pieces in a commercial venue, business setting, the hospitality sector or in private residences.

Crafted entirely in solid wood, it was designed so there's no distinction between the table top and frame. The top is flat with a slightly domed shape underneath, which is mirrored in the base. Because of its solidity, Pon is an ideal addition to public spaces in need of a sturdy, durable, versatile table.

				
Jasper Morrison, 2016	Model 1280 Side Table Ø 35 H 36 cm	Model 1285 Side Table Ø 40 H 41 cm	Model 1290 Side Table Ø 45 H 46 cm	Model 1295 Coffee Table Ø 90 H 38 cm

Wood:
Oak soap, Oak light oil, Smoked oak oil, Oak black lacquered.

Wood:
Oak soap, Oak light oil, Smoked oak oil, Oak black lacquered.

Wood:
Oak soap, Oak light oil, Smoked oak oil, Oak black lacquered.

Wood:
Oak soap, Oak light oil, Smoked oak oil, Oak black lacquered.

PRODUCT SHEET DOWNLOAD
FREDERICIA.COM

Pon Table

Pon Table
Wood:
Oak soap
Oak light oil
Oak black lacquered



An asymmetrical equilibrium

It's rare to find coffee tables that are asymmetrical yet balanced. Organic but still graphic. Such is the case with the Insula Table series by Ernst & Jensen.

The slim, curved table top is supported by an angular frame, resulting in a truly distinctive design conceived in three sizes, which each attain a perfect sense of equilibrium. Almost like small islands, the tables have a floating feeling. Their striking silhouette makes them equally as beautiful as stand-alones or clustered together to form an archipelago.

The powder-lacquered aluminium frame with a matching lacquered top give the tables a clean, monochromatic look. Ideal for blending into the décor of a hotel lobby, reception area at work or living room at home.



Anne-Mette Bartholin Jensen
& Morten Ernst, 2009/14

Model 5190
Coffee Table
D 72 W 76 H 30 cm

Model 5191
Coffee Table
D 95 W 98 H 34 cm

Model 5192
Coffee Table
D 118 W 121 H 38 cm

Model 5198
Side Table
D 47 W 40 H 38/58 cm

Base:
Black aluminium

Table top:
Black aluminium

Base:
Black aluminium

Table top:
Black aluminium

Base:
Black aluminium

Table top:
Black aluminium.

Base:
Black aluminium

Table top:
Black aluminium

PRODUCT SHEET DOWNLOAD
FREDERICIA.COM

Insula Table

Insula Table
Black aluminium

Delphi Sofa
Upholstery: Fiord 191
Base: Brushed aluminium

Hydro Vase

Locus Bowl





Picolo Table. Black aluminium.
Delphi Sofa. Upholstery: Leather Max 95 Cognac.
Insula Table. Black aluminium.



Insula Table. Black aluminium.

Like a companion

Just as its name suggests, Pal is there whenever you need it. It's a small, occasional table that's movable and easy to access.

For Milan-based, Japanese designer Keiji Takeuchi, simplicity is the path to sophistication. Seen in Pal's solid wood table top crafted to resemble a serving tray and slim stem and base in stainless steel, with the option of a powder-coated base. Solid wood and well-crafted steel are rich materials that will acquire a beautiful patina over time. What's more, they blend seamlessly with other materials and colour schemes in virtually any interior.

A variety of table top sizes and the ability to choose a preferred height makes Pal a versatile design you can personalise. Takeuchi often describes his designs as "living objects", referring to aspects not necessarily visible or tangible. But rather, something you can sense from their presence.

Keiji Takeuchi, 2020



Model 6751
Side Table
Ø 37,5 H 38/45/52 cm



Model 6755
Side Table
Ø 44 H 38/45/52 cm

Table top:
Oak light oil, Oak black lacquered,
Walnut oil.

Base:
Black, Brushed stainless steel

Table top:
Oak light oil, Oak black lacquered,
Walnut oil.

Base:
Black, Brushed stainless steel

PRODUCT SHEET DOWNLOAD
FREDERICIA.COM

Pal Table

EJ315
Upholstery: Leather Primo 88 Black
Legs: Oak light oil

Pal Table
Table top: Walnut oil
Base: Black

Silhouette Mirror
Wood: Walnut



A strong, assertive identity

The Islets Table series is a precise design with a strong identity, based on a simple construction, where details are kept to a minimum. It's an approach that reflects the sculptural minimalism of designer Maria Bruun, who seeks a balance between a light feeling in the expression and pieces with a strong, assertive presence.

Islets consists of a side table, a large coffee table and a grand dining table all crafted in solid oak and finished with a natural light oil. Oak is a signature material from Fredericia, appreciated for its warmth and durable qualities. The series can work as separate elements or as a set to anchor an interior - from private homes to public spaces.



Model 6775
Dining Table
Page 318

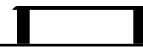

Model 6772
Coffee Table
W 110 L 110 H 30 cm



Model 6770
Side Table
W 40 D 40 H 50 cm

Maria Bruun, 2020

Wood:
Oak light oil

Wood:
Oak light oil

PRODUCT SHEET DOWNLOAD
FREDERICIA.COM

Islets Table



A slim line floating in space

The word "piloti" refers to the pillars or columns that elevate a building above the ground. While the legs of our Piloti Tables resemble pillars, the overall intention is for the table to appear like a slim line almost floating in space. An elegant integration of the table top with the legs ensures a subtle, streamlined transition into one balanced entity.

Light in appearance yet sturdy in construction, the Piloti tables in wood are made from solid oak, a naturally beautiful, tactile material that needs no adornment. The option of different sizes gives you the freedom to cluster the tables together in a corner or as part of a sofa set-up. Place them individually as side tables or as a matching pair on either side of a bed.

Hugo Passos, 2016					
	Model 6700 Side Table L 39 W 31 H 35/41 cm	Model 6705 Side Table L 46,5 W 39 H 35/41 cm	Model 6715 Coffee Table L 120 W 39 H 35/41 cm	Model 6720 Coffee Table L 75 W 75 H 35/41 cm	Model 6725 Coffee Table L 63 W 63 H 35/41 cm

Wood:
Oak light oil, Oak black lacquered,
Smoked oak oil.

Wood:
Oak light oil, Oak black lacquered,
Smoked oak oil.

Wood:
Oak light oil, Oak black lacquered,
Smoked oak oil.

Wood:
Oak light oil, Oak black lacquered,
Smoked oak oil.

Wood:
Oak light oil, Oak black lacquered,
Smoked oak oil.

PRODUCT SHEET DOWNLOAD
FREDERICIA.COM

Piloti Table

Piloti Table
Wood: Oak oil



No two are alike

Adding to Piloti's tangible materiality is our Piloti Stone Table variant, featuring a stone table top supported by steel legs. Each table top is one-of-a-kind, with its own subtle differences in surface patterns and tonalities. We've applied our expertise in craftsmanship to create a unique profile never seen before in this type of stone table.

The sleek marble top transitions gracefully with the sturdy cylindrical legs. The result is a seamless visual impression that makes Piloti in Stone an ideal statement piece, whether for private homes, hotels or executive settings.

Hugo Passos, 2019



Model 6760
Coffee Table
L 75 W 39 H 35 cm



Model 6750
Coffee Table
L 75 W 75 H 35 cm

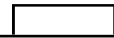

Model 6745
Coffee Table
L 120 W 39 H 35 cm

Stone:
Grey Pietra marble

Base:
Flint

Stone:
Grey Pietra marble

Base:
Flint

Stone:
Grey Pietra marble

Base:
Flint

PRODUCT SHEET DOWNLOAD
FREDERICIA.COM

Piloti Stone Table



Simple, elegant and easy

Simple, elegant, and easy, just like the original Piloti design. The robust aluminium frame meets all current requirements for flexible and long-lasting furniture while being able to change expression depending on the choice of tabletop. The construction is classic and durable, making it an obvious table for public places and corporate environments, as well as private homes.

Hugo Passos, 2021



Model 6610
Coffee Table
L 75 W 39 H 35 cm

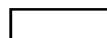

Model 6615
Coffee Table
L 120 W 39 H 35 cm



Model 6620
Coffee Table
L 75 W 75 H 35 cm

Table top:
White Carrara, Black Marquina.

Base:
Black lacquered aluminium, Polished aluminium.

Table top:
White Carrara, Black Marquina.

Base:
Black lacquered aluminium, Polished aluminium.

Table top:
White Carrara, Black Marquina.

Base:
Black lacquered aluminium, Polished aluminium.

PRODUCT SHEET DOWNLOAD
FREDERICIA.COM

Piloti Alu Table



The stunning appeal of stone

It's quite an accomplishment to craft the Tableau Coffee Table in stone, creating synergy with the soft-corned square top and the x-shaped base. Stone has a universal appeal as an exclusive material, with subtle differences in surface patterns unique to each piece.

Available in three versions, the Tableau series in stone makes for a subtle yet striking statement that's ideal in a variety of venues. Such as private homes, as well as luxurious hotels, upscale restaurants and exclusive lounges. Virtually any interior where you want to signal a look that's timeless and unquestionably elegant.

Space Copenhagen, 2018



Model 1960
Coffee Table
Ø 100 H 40 cm



Model 1965
Coffee Table
L 140 W 140 H 40 cm



Model 1966
Coffee Table
L 100 W 100 H 40 cm

Stone:
Dark Atlantico limestone

Stone:
Dark Atlantico limestone

Stone:
Dark Atlantico limestone

PRODUCT SHEET DOWNLOAD
FREDERICIA.COM

Tableau Coffee Table

Tableau Table
Ditzel Lounge Chair
Upholstery: Sheepskin
Legs: Walnut lacquered
Calmo sofa
Upholstery: Sunniva 717
Base: Black
Mogensen 6386 Table
Wood: Oak light oil
BM61/BM62 Chair
Cane Wicker, Natural
Wood: Oak oil



Contemporary cool

Sleek in appearance, stable in construction and modern in its expression, the EJ66 Coffee Table is a contemporary classic worth coveting. The marble table top has an intrinsic beauty that adds depth to the design. A natural, long-lasting, robust material in contrast to the cool look of the stainless-steel legs.

Johannes Foersom &
Peter Hiort-Lorenzen, 1999



Model 5165
Coffee Table
W 80 D 80 H 38 cm



Model 5166
Coffee Table
W 130 D 45 H 38 cm

Stone:
White Carrara, Black Marquina,
Grey Pietra.

Base:
Brushed stainless steel,
Black.

Stone:
White Carrara, Black Marquina,
Grey Pietra.

Base:
Brushed stainless steel,
Black.

PRODUCT SHEET DOWNLOAD
FREDERICIA.COM

EJ66 Coffee Table

EJ66 Table
Table top: White Carrara
Base: Brushed stainless steel

EJ220 Elements
Upholstery: Bardal 220
Legs: Oak soap



A classic piece

Designed in 1960, along with Ox Chair and Queen Chair, the Ox Table fits as a natural centrepiece. A classic Hans. J. Wegner piece of furniture in a simple, yet complex design with a self-supporting construction completed without any side rails resulting in a sleek and elegant profile. The table is available in two heights, and more tables can put together with overlapping table tops.

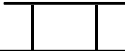
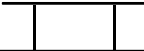
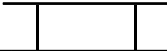
Hans. J. Wegner, 1960				
	Model 1028 Coffee Table Ø 80 H 35 / 41 cm	Model 1020 Coffee Table Ø 100 H 35 / 41 cm	Model 1022 Coffee Table Ø 120 H 35 / 41 cm	Model 1025 Coffee Table Ø 150 H 35 / 41 cm
	Table top: Walnut oil, Oak lacquered, Oak oil.	Table top: Walnut oil, Oak lacquered, Oak oil.	Table top: Walnut oil, Oak lacquered, Oak oil.	Table top: Walnut oil, Oak lacquered, Oak oil.
	Base: Brushed stainless steel.	Base: Brushed stainless steel.	Base: Brushed stainless steel.	Base: Brushed stainless steel.
PRODUCT SHEET DOWNLOAD FREDERICIA.COM				

Wegner Ox Table



Complements

Complements is our line of material-driven objects conceived as collector pieces to complement our portfolio of products. The collection extends from objects to small functional furniture. We've engaged with the next wave of talent in Denmark and abroad. Both new and established names, who share our affinity for honest materials, compelling shapes, surface textures and exceptional craftsmanship. Complements encompasses an array of items that - together with our line of furniture - create a look and feel for an entire interior. Each object is distinctive, yet they all reflect our pioneering spirit to create essentials with presence and permanence.

Meadow Lamp	374
Fellow Lamp	376
Hydro Vase	378
Locus Bowl	380
Silhouette Mirror	382
Sequoia Pouf	384
JG Folding Stool	386
Nara Coat Stand	388
Gallery Stool	390
Magazine Table	392





The soft light of late summer

Made from solid stone, glass and brass, Meadow is a table lamp that balances materiality with light. A simple composition of a dome-shaped shade that is mirrored in the more diminutive stone base gives Meadow an organic, unassuming look.

The name Meadow was inspired by the soft emission of light and mushroom shape, reminiscent of a lovely meadow in late summer. Able to add a gentle illumination to all kinds of interiors, from commercial and hospitality settings to private homes.



Space Copenhagen, 2020

Model 8115
Lamp
Ø 24 H 30 cm

Base:
Dark Atlantico limestone
Shade:
White opal glass

PRODUCT SHEET DOWNLOAD
[FREDERICIA.COM](https://www.fredericia.com)

Meadow Lamp

Meadow Lamp

Pal Table

Table top: Oak light oil
Base: Brushed stainless steel

Hector Sofa

Upholstery: Leather Max 92 Tam
& Natural Canvas
Legs: Brushed stainless steel



Organic & endearing

Fellow is both a table lamp and a sculpture in its own right. Designed by Space Copenhagen, who sought to create a simple, intuitive composition from two soft, distinctive, organic-shaped elements. When combined together, it's as if they represent the head and body of a small, kind creature with its own quiet, yet strong identity. The base is made from solid limestone, which renders it visually and technically static.

Space Copenhagen, 2020



Model 8110
Lamp
W 21 D 35 H 35 cm

Base:
Dark Atlantico limestone

Shade:
White painted steel

PRODUCT SHEET DOWNLOAD
[FREDERICIA.COM](https://www.fredericia.com)

Fellow Lamp

Fellow Lamp
Pal Table
Table top: Oak light oil
Base: Brushed stainless steel



Referencing ancient Greek vessels

Referencing classic ceramic vases and ancient Greek vessels The Hydro Vase makes a modern statement that incorporates the material properties and appeal of brass.

Chosen because it can be shaped in ways that resemble iconic pottery, brass exudes even more character with a patina that will gradually emerge over time. With Hydro, Copenhagen-based designer Sofie Østerby establishes an equilibrium between the visual impact of the brass and the shape itself.

Hydro is cast by a small workshop in Portugal that has retained the ancient technique of creating traditional armour. The dark, almost black oxidised surface adds a subtle dimension to an enduring design that seems to defy time. Culminating in a vase that doubles as a decorative sculpture. Classic yet contemporary – and collectible.

Sofie Østerby, 2020



Model 8210
Vase
Ø 15 H 20 cm



Model 8211
Vase
Ø 22,5 H 30 cm

Material:
Casted solid brass with black
oxidized surface treatment

Material:
Casted solid brass with black
oxidized surface treatment

Sofie Østerby, 2022



Model 8208
Vase
Ø 15 H 20 cm



Model 8209
Vase
Ø 22,5 H 30 cm

Material:
Glass

Material:
Glass

PRODUCT SHEET DOWNLOAD
FREDERICIA.COM

Hydro Vase



Unique textures & tonalities

The Locus Bowl is a modern design inspired by traditional stone carving techniques. A decorative bowl, elegantly proportioned and exceptionally crafted with grooves around the outer edge as a graphic expression of the stone carving process. With the choice of travertine, Locus embodies designer Sofie Østerby's intuitive approach to balancing material presence and shape. Travertine is a material native to Italy, used in classical architecture for centuries.

Interestingly, travertine used to have a counterpart in Denmark. The natural limestone that was mined in the Faxe area south of Copenhagen is similar in appearance and composition to travertine, which makes it familiar in a Nordic design context, as well. Locus is crafted in raw Italian travertine, where the natural, irregular surface is kept intact to highlight the innate beauty of the material properties, boasting unique textures and tonalities that will vary from piece to piece. Making each Locus Bowl a collectible.

Sofie Østerby, 2020

Model 8215
Bowl
Ø 40 H 7 cm

Material:
Solid travertine with drilled grooves

PRODUCT SHEET DOWNLOAD
FREDERICIA.COM

Locus Bowl



Timeless & Trendless

Silhouette is a series of mirrors framed in solid wood, informed by a focus on materials, craftsmanship and the experience of living with design. The concept is based on a simple geometric equation – a round, a square and a rectangle as universal shapes that are timeless, trendless and at the same time, contemporary. Designed by Copenhagen-based OEO Studio, the warmth of the walnut frame coupled with careful detailing add sophistication and a classic feel.

A discrete, well-crafted facet and visible splines in the joints are subtle, unadorned design details that honour the essence of a mirror. The lovely wood grain pattern is enhanced by the oiled surface reflecting a graceful use of materials. Add Silhouette to a small space and watch for a feeling of expansion. Incorporate it into a large space and you have an instant sense of intimacy.



OEO Studio, 2020

Model 8324
Rectangular Mirror
W 70 H 180 D 3,5 cm

Model 8320
Circular Mirror
Ø 100 D 3,5 cm

Model 8322
Square Mirror
W 70 H 70 D 3,5 cm

Frame:
Walnut oil

Frame:
Walnut oil

Frame:
Walnut oil

PRODUCT SHEET DOWNLOAD
FREDERICIA.COM

Silhouette Mirror

Canvas Chair
Canvas: Black
Wood: Oak black lacquered
Meadow Lamp
Mono Pouf
Upholstery: Leather Omni 301 Black



Soft & sculptural

The iconic Sequoia tunnel tree was the inspiration for Space Copenhagen's design of the Sequoia Pouf. In contrast to the gigantic American redwood, the Sequoia Pouf is compact, moveable and versatile. Sequoia features soft contours and a feeling of seamless upholstery, in either flat woven wool, bouclé or fluffy sheepskin.

Key to the Sequoia Pouf's distinctive appeal is the sculptural shape with its curved edges. It's an inventive, multi-purpose design that's ideal as a stool or a place to put a book, as well as a decorative element for hotels and hospitality, retail venues, commercial settings and residences. Or simply as a contemporary conversation piece boasting a quiet presence with personality.



Space Copenhagen, 2020

Model 1756
Pouf
Ø 40 H 42 cm

Upholstery:
Bouclé, Wool or Sheepskin.

PRODUCT SHEET DOWNLOAD
FREDERICIA.COM

Sequoia Pouf



A masterpiece in engineering

Launched in 1970, the JG Folding Stool earned designer Jørgen Gammelgaard the prestigious Danish Furniture Prize the following year. Since then, the JG Folding Stool has achieved iconic status. The sleek, stainless steel legs expand to create a frame comprised of diagonal lines supporting a simple seat in Aniline leather or canvas. When in a folding position, all the elements easily collapse together.



Jørgen Gammelgaard, 1970

Model 6565
Stool
W 60 D 46 H 40 cm
SH 40 cm

Frame:
Brushed stainless steel

Seat:
Natural canvas, Leather

PRODUCT SHEET DOWNLOAD
FREDERICIA.COM

JG Folding Stool

JG Folding Stool
Frame: Brushed stainless steel
Seat: Natural canvas



A symbolic wink to deer antlers

Japanese designer Shin Azumi recycled remnants from wood production to create the Nara Coat Stand. A sculptural expression of a functional object intended to capture the beauty of solid timber in a simple wooden structure. Alluding to deer antlers, as referenced by the name Nara, Japan's historical capital city known for its free roaming deer.



Shin Azumi, 2009

Model 1880
Coat Hanger
W 32 D 42 H 180 cm

Variants:
Oak lacquered with white base
Black lacquered with black base

PRODUCT SHEET DOWNLOAD
FREDERICIA.COM

Nara Coat Stand



A sense of completeness

Launched in 1998, the Gallery Stool marked a major breakthrough that pushed the parameters of moulded plywood to the limit. A move that led to numerous international awards and accolades. It's a lyrical sculpture that doubles as a stool, where emphasis is on the simple curves that convey a sense of completeness.



Hans Sandgren Jakobsen, 1998

Model 1610
Stool
W 52 D 36 H 48 cm
SH 42,5 cm

Wood:
Black lacquered, Walnut lacquered.

[PRODUCT SHEET DOWNLOAD](#)
[FREDERICIA.COM](#)

Gallery Stool



An iconic collectible

Sweeping diagonal lines with softened cut-outs and curves echo Jens Risom's penchant for practicality in this functional magazine table with a striking, sculptural silhouette. Ideal for any contemporary setting from hotels to private homes. An iconic design from 1949 that appeared in the first comprehensive catalogue from Risom with the slogan "Furniture with a signature."



Jens Risom, 1949

Model 6500
Magazine Table
L 57,5 W 40,5 H 47 cm

Wood:
Oak lacquered, Black lacquered.

PRODUCT SHEET DOWNLOAD
[FREDERICIA.COM](https://www.fredericia.com)

Magazine Table



Visual Index



BM61 Chair & BM62 Armchair	72
Eyes	110
Flamingo Chair	94
J39 Mogensen Chair	30
J64 Chair & J63 Stool	58
Lynderup Chair	44
Mogensen Bench & 3236 Chair	62
Pato Executive	132
Pato Sledge	136
Pato Swivel & Pato Office	128
Pato Wood Base	126
Pato 4 Leg	118
Plan Chair	38
Post Chair	52
The Spanish Dining Chair	68
Spine	102
Swoon Chair	96
Søborg Chair	78
Trinidad Chair	88
Yksi Chair	84

The A-Chair	204
Calmo Chair & Calmo Ottoman	222
The Canvas Chair	158
Corona Chair & Corona Ottoman	198
Ditzel Lounge Chair	194
Eyes Lounge	218
The Hunting Chair	150
Mogensen 2334 Lounge Chair	156
Mono Pouf	224
Pato Lounge	214
Savannah Chair	208
Savannah Chair Petit	212
The Spanish Chair	144
Spine Lounge Chair	190
Swoon Lounge Petit	186
Swoon Lounge & Swoon Ottoman	178
Wegner Ox Chair	164
Wegner Queen Chair	170
Wegner J16 Rocking Chair & Stool	172
Wegner 1788 Easy Chair	176
2207 Chair, 2204 Wing Chair & 2202 Ottoman	152

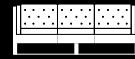

Calmo Sofa	270
Delphi Elements	242
Delphi Sofa	240
EJ220 Elements	300
EJ220 Sofa	298
EJ280 Elements	290
EJ280 Sofa	284
EJ288 Sofa	292
EJ295 Chaise Sofa	296
EJ315 Sofa	252
Haiku Sofa	280
JG Sofa	264
Konami Sofa	276
Mogensen Coupé Sofa	236
Mogensen 2208 & 2209 Sofa	234
Mogensen 2212 & 2213 Sofa	230
Mogensen 2335 & 2333 Sofa	238
No.1 Sofa	262
Savannah Sofa	268
Spine Lounge Sofa & Daybed	248
The Spoke-Back Sofa	258

Tables



Coffee Tables



Ana Table	334
BM71 Library Table	306
C18 Table	308
Islets Dining Table	316
JG Table	322
Mesa Table	338
Post Table	330
Taro Table	326
6284 Table	310
6286 & 6386 Table	312
EJ66 Coffee Table	364
Insula Table	348
Islets Table	354
Pal Table	352
Piloti Alu Table	360
Piloti Stone Table	358
Piloti Table	356
Pon Table	346
Tableau Coffee Table	362
Wegner Ox Table	366



Fellow Lamp	376
Gallery Stool	390
Hydro Vase	378
JG Folding Chair	386
Locus Bowl	380
Magazine Table	392
Meadow Lamp	374
Nara Coat Stand	388
Sequoia Pouf	384
Silhouette Mirror	382

Designers

Masters

Børge Mogensen
Ejvind A. Johansson
Erik Ole Jørgensen
Erik Jørgensen
Hans J. Wegner
Hannes Wettstein
Jens Risom
Jørgen Gammelgaard
Nanna Ditzel
Poul M. Volther

Designers



Børge Mogensen
1914 – 1972

Børge Mogensen was one of the most influential designers in shaping Danish Modern, and defined the design vision of Fredericia from 1955 until his death in 1972. Mogensen's most recognised pieces were developed during his collaboration and friendship with Fredericia CEO Andreas Graversen.

Included in collection:
The Spanish Chair, The Hunting Chair, Mogensen Bench, 3236 Chair, J39 Chair, Mogensen Tables, Søborg, No. 1 Sofa, Spoke-Back Sofa, 22 Collection, 23 Collection Canvas Chair, BM61 Chair, BM62 Armchair.



Hans J. Wegner
1914 – 2007

World-renowned designer of iconic Danish chairs, Hans J. Wegner was keen on infusing his functional designs with a poetic and playful edge. His training in furniture making further nurtured his love of wood and sculptural lines. Together with Mogensen, he helped make mid-century Danish design popular on an international scale.

Included in collection:
J16 Rocking Chair, J16 Stool, 1788 Chair, Queen Chair, Ox Chair, Ox Table.



Nanna Ditzel
1923 – 2005

With her post-modern attitude and rebellious take on tradition, Nanna Ditzel became a leading figure in the renewal of Danish design in the 1990s. She had an amazing ability to transform her artistic dreams into functional and purposeful designs, often starting from a perspective that questioned assumptions about design. Daring to challenge the status quo.

Included in collection:
Trinidad, Ditzel Lounge Chair.

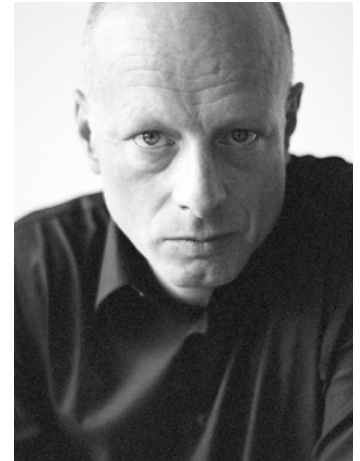

Hannes Wettstein
1958 – 2008

Swiss designer Hannes Wettstein was an influential talent within industrial design, furniture and architecture. He had a willingness to rethink everything determined by design – from human behaviour and how rooms are organised to the purpose of things. His impulse to investigate led to refreshing solutions reflecting his passion for art and technology.

Included in collection:
Delphi & Ottoman, Delphi Elements.

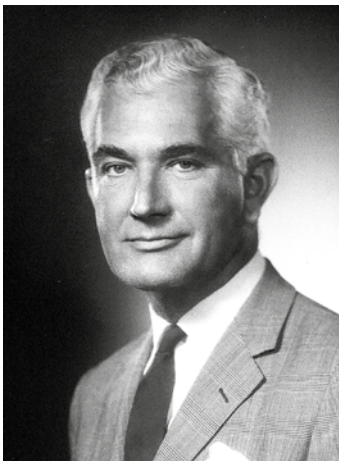

Jens Risom
1916 – 2016

Danish-American furniture designer Jens Risom was one of the first to introduce a Scandinavian sense of aesthetics to America. There he made a name for himself with his stylish approach to timeless, functional designs and focus on natural materials. He was a key figure who contributed to the Danish Modernism movement, with designs characterised by their quiet confidence, character and understated elegance.

Included in collection:
A-Chair, Magazine Table.



Erik Ole Jørgensen
1925 – 2002

During his career as a designer and architect, Erik Ole Jørgensen showcased his instinct for tactility and intuitive understanding of materials in an array of furniture as well as fabric designs. Armed with an uncanny sense of composition, his work signals a timeless, effortless elegance. Clean, uncluttered concepts in classics executed with expert detailing and craftsmanship.

Included in collection:
EJ315

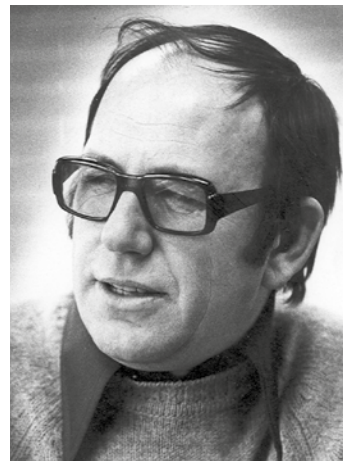

Erik Jørgensen
1928-1998

Craftsmanship skills were the foundation for Erik Jørgensen to establish his own furniture upholstery workshop in 1954. Trained as a saddler and upholsterer, his understanding of materials, passion for furniture and knowledge of market trends propelled him to design a number of sofa collections. Simple, functional, durable designs of high quality, exemplifying his exceptional competences within sofa design and upholstery expertise.

Included in collection:
EJ220, EJ280, EJ288, EJ295.

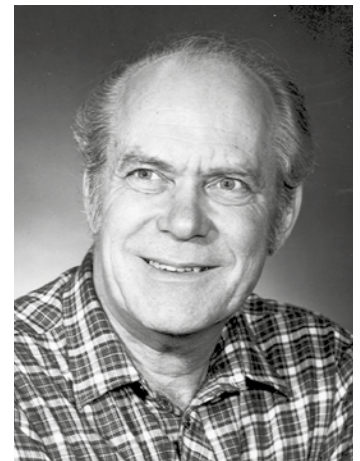

Poul M. Volther
1923 – 2001

Poul M. Volther was an important champion of Scandinavian functionalism. Although rooted in a rationalist design dogma and inspired by the purpose-driven mindset of the Bauhaus movement, Volther was eager to experiment with new methodologies. His unerring sense of detail and appreciation of material properties resulted in simple, stylised furniture with a subtle yet striking aesthetic.

Included in collection:
Corona Chair

Contemporary

Anne-Mette Bartholin Jensen & Morten Ernst
Arde
Birgitte Due Madsen & Jonas Trampedach
Cecilie Manz
Damian Williamson
Edward Barber & Jay Osgerby
GamFratesi
Hans Sandgren Jakobsen
Hugo Passos
Jasper Morrison
Johannes Foersom & Peter Hiort-Lorenzen
Keiji Takeuchi
Maria Bruun
Monica Förster
OEO Studio
Shin Azumi
Sofie Østerby
Space Copenhagen
Thau & Kallio
Welling / Ludvik

Designers



Cecillie Manz

With a discrete sense of playfulness, Cecillie Manz's work demonstrates that functional details capture the aesthetic essence of an object in a subtle way. Considered one of the leading Danish furniture designers of her generation, all her projects have a strong, functional reason for revolving around simplicity, in her mission to create a pure, aesthetic object.

Included in collection:
Post Chair, Post Table.



Edward Barber & Jay Osgerby

Edward Barber and Jay Osgerby founded their East London studio in 1996 after studying architecture at the Royal College of Art. For more than two decades, their work has challenged the boundaries of design internationally. Barber and Osgerby work with leading global manufacturers, including Vitra, Knoll, B&B Italia, Flos, Venini and Hermès.

Included in collection:
Plan Chair, Plan Table.



Hugo Passos

Portuguese-born, Copenhagen based designer Hugo Passos designs everyday objects that are familiar and enjoyable, both in form and use. Passos' work is inspired by his ongoing interest in the human scale of everyday objects. Along with his commitment to the idea that his designs must serve a purpose and do what they are intended to do.

Included in collection:
Piloti Table, Calmo Sofa.



Jasper Morrison

Jasper Morrison is a British multi-disciplinary designer, well known for creating the "Super Normal" concept. A creative credo reflecting his idea of good design. Celebrated for his no frills, minimalistic approach, Morrison is a highly productive designer who divides his time between studios in London and Tokyo.

Included in collection:
Pon Table, Taro Table.



Maria Bruun

Danish designer Maria Bruun creates unique experiences in form and space. Much like a set designer, early in her creative process she visualises her ideas in a spatial context in relation to its surroundings. An approach that contributes to her carefully considered, sculptural designs that are a pleasure to both use and behold.

Included in collection:
Islets Dining Table, Islets Side Table.



Monica Förster

Born and raised in Sweden close to the Arctic Circle, Monica Förster has authored some of the most international-celebrated objects in contemporary Swedish design. Her curiosity about materials and methods has led to her cross-disciplinary approach, involving a mix of innovative and traditional craft techniques in her personal interpretation of design genres.

Included in collection:
Savannah Chair, Savannah Sofa.



Space Copenhagen

The design duo Space Copenhagen continues to make headlines with their signature style of elegant yet classic design lines imbued with a contemporary edge in an approach they call Poetic Minimalism. Ideas that emerge from intuition and emotion. In their work with Fredericia, they seek to rethink upholstery traditions in practice at our factory for more than 100 years.

Included in collection:
Spine Collection, Swoon Collection, Tableau Coffee Table, Meadow Lamp, Fellow Lamp, Sequoia Pouf.



Welling/Ludvik

The Danish-Icelandic duo Welling/Ludvik prove that the basics can always be reinvented. They define their aesthetic as pure, stripping away any excess and letting each detail serve a functional purpose. Traditional virtues of Scandinavian design, re-booted using modern materials and production technology. Based on their belief that good design never loses its ability to be interesting, even when reduced to its simplest form.

Included in collection:
Pato Collection, Mesa Table.

Special thanks to:

Wichmann & Bendtsen, Apollo Bar, Yellows Studio, Enok Holsegaard, Copenhagen Contemporary, V1 Gallery, Sunday-S Gallery, Frederik Ravn Rønne Kastrupsen, Stephan Thordal, Work Club Global, The Jane, Pieter D'Hoop, Multiform Copenhagen, Aarhus University, Atelier the Vijzel, Ambassador House, Zürich, Clemens Bachmann Architects, Zurich Innovation Center, Georg Aerni, Fayland House, London, Simon Menges and Stephan Julliard, Kit Haselden Photography, Park House on Finsbury Circus, London Kilian O'Sullivan, The Standard Copenhagen, Ordrupgaard, Neel, Munthe Bruun, Mads Flummer, Court house Svendborg, Tadaima Cph, Kirsten Lillelund, Hollands Licht, Tina Marie, Nina Nørgaard, Birgitte Due, Seche Studio, FLOS, Gertrud Vasegaard, Holmegaard, Martin Friis, Cecilie Holbech, Twenty Twentyone, Barber & Osgerby, OMHU studio, Matias Mollenbach, Sofie Østerby, Malene Knudsen, Helle Mardahl, Tilde Grynnderup, Astep, Sara Jeffries, Stine Bidstrup, Society Limonta, Sandra Davolio, Artemide, A Hint of Neon, STODEOH, Noa Gammelgaard, Michael Anastasiades, Anour, Ingo Mauer, Alessi, Tora Frogner.

Graphic design:
Studio Peter Christensen

Fredericia Furniture A/S
Treldevej 183
7000 Fredericia
www.fredericia.com
info@fredericia.com
+45 7592 3344

Copenhagen Showroom
Løvstræde 1, 4th & 5th floor
1152 Copenhagen

London Showroom
1 Dufferin Street
London EC1Y 8NA

Oslo Showroom
Drammensveien 120
0277 Oslo

Follow us:
[@fredericiafurniture](https://twitter.com/fredericiafurniture)
[#fredericiafurniture](https://hashtagger.com/#fredericiafurniture)
[#modernoriginals](https://hashtagger.com/#modernoriginals)



